

# Front Brake Caliper Removal/Installation

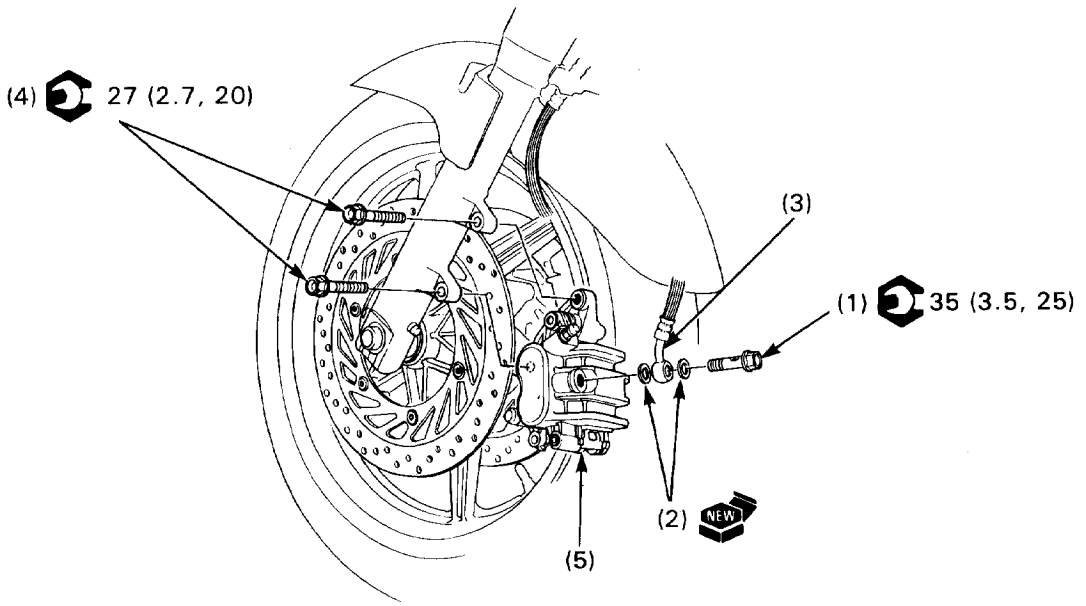

**⚠ WARNING**

- A contaminated brake disc or pad reduces stopping power. Discard contaminated pads and clean a contaminated disc with a high quality brake degreasing agent.
- Inhaled asbestos fibers have been found to cause respiratory disease and cancer. Never use an air hose or dry brush to clean brake assemblies. Use an OSHA-approved vacuum cleaner or alternate method approved by OSHA designed to minimize the hazard caused by airborne asbestos fibers.

**NOTE**

- If you remove the caliper pistons, remove the caliper bracket bolts (4) before disconnecting the brake hose (3) ; and place a pan under the caliper to catch the draining fluid and squeeze the brake lever slowly to push out the pistons.

**Requisite Service**

- Brake pad removal/installation (page 14-2)
- Brake fluid replacement/air bleeding (section 17 of the Common Service Manual)

Procedure	Q'ty	Remarks
<b>Removal Order</b>		• Installation is in the reverse order of removal.
(1) Brake hose bolt	1	
(2) Sealing washer	2	
(3) Brake hose	1	At installation, press the hose end against the stopper while tightening the hose bolt.
(4) Caliper bracket bolt	2	
(5) Front brake caliper assembly	1	