

Front Brake Pad Replacement

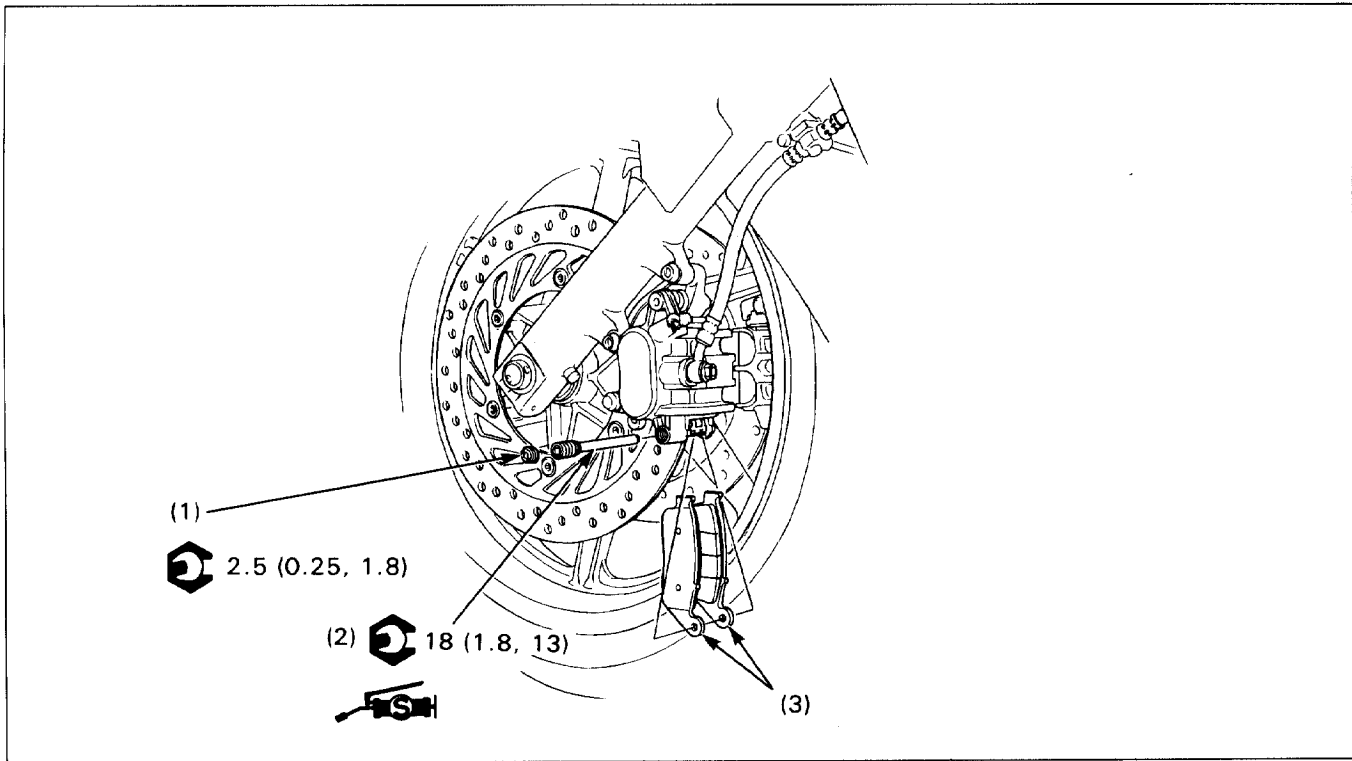

⚠ WARNING

- A contaminated brake disc or pad reduces stopping power. Discard contaminated pads and clean a contaminated disc with a high quality brake degreasing agent.
- Inhaled asbestos fibers have been found to cause respiratory disease and cancer. Never use an air hose or dry brush to clean brake assemblies. Use an OSHA-approved vacuum cleaner or alternate method approved by OSHA designed to minimize the hazard caused by airborne asbestos fibers.

NOTE

- Do not depress the brake lever when the caliper is removed, or it will be difficult to refit the disc between the brake pads.
- Replace brake pads as a set.
- Apply a thin coat of silicone grease onto the pad pin as a rust preventative.

Requisite Service

- Pushing the caliper against the disc, push the caliper pistons all the way in to allow the installation of new brake pads.

Procedure		Q'ty	Remarks
Removal Order			• Installation is in the reverse order of removal.
(1)	Pad pin plug	1	
(2)	Pad pin	1	Insert the pin, pushing the pads against the pad spring.
(3)	Brake pad	2	Align the pad lug with the pad retainer as shown.