

## Engine servicing

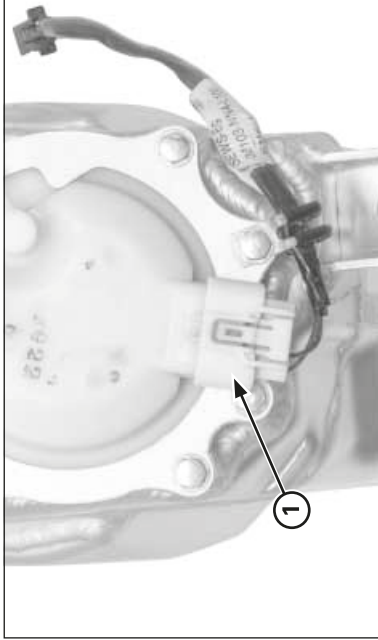

(1) 5P CONNECTOR

### Disassembly / Installation of fuel feed hose

The pawl of the fast connector must be changed every time the fuel feed hose is disconnected.

#### Disassembly of fuel pump side

Stop the engine.  
Remove the seat, front covers, side covers and the seat-rear fender assy.  
Remove the rear fender  
Pull up the fuel tank  
Disconnect the fuel pump's 5P connector.  
Turn on the engine until it stops.

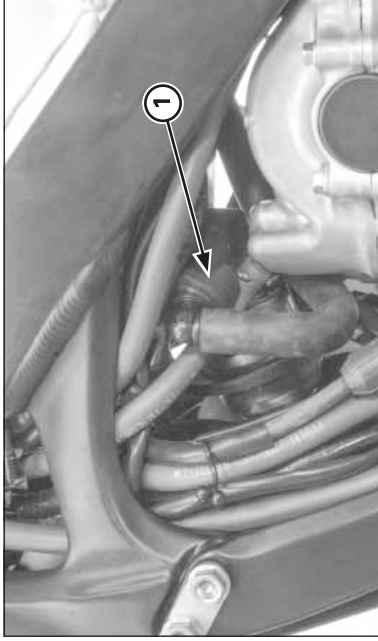

(1) FAST CONNECTOR PROTECTOR

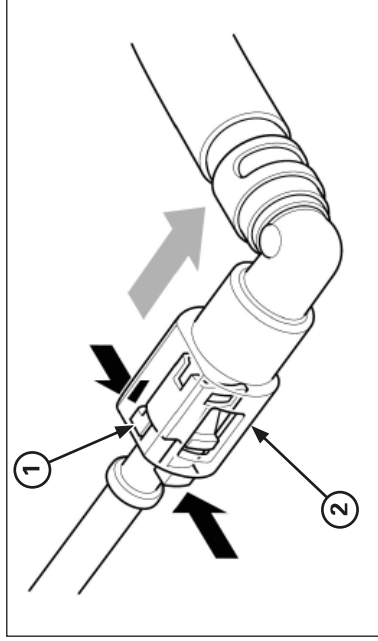

(1) PAWL  
(2) FAST CONNECTOR

1. Remove the protective housing from the fast connector.
2. Check whether the connector is dirty and clean if necessary. Cover the fast connector with a cloth.
3. Hold fast connector with one hand and tighten the two pins of the pawl with the other hand while pulling the connector backwards. Disconnect the fast connector and remove the pawl.

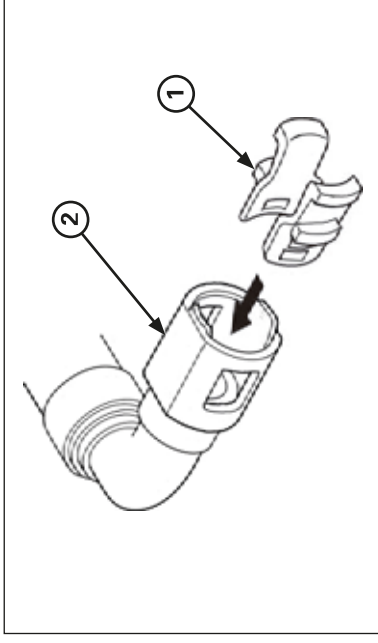

(1) PAWL  
(2) FAST CONNECTOR

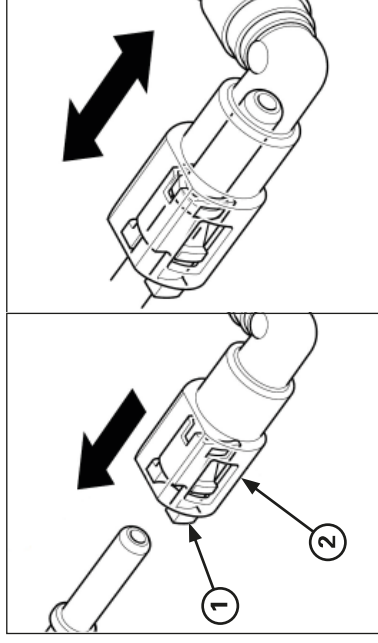

(1) PAWL  
(2) FAST CONNECTOR

#### Installation of fuel pump side

1. Insert a new pawl in the fast connector. Insert the fast connector in the fuel pump feed hose until it clicks. If this is hard to do, apply a small amount of motor oil to the fuel pump feed hose.
2. Move the fast connector backwards to check that it does not come out and is firmly connected.
3. Place the protective housing over the fast connector.