

## Camshaft Installation

Turn the crankshaft clockwise and align the "T" mark on the pulse rotor with the index mark on the left crankcase.

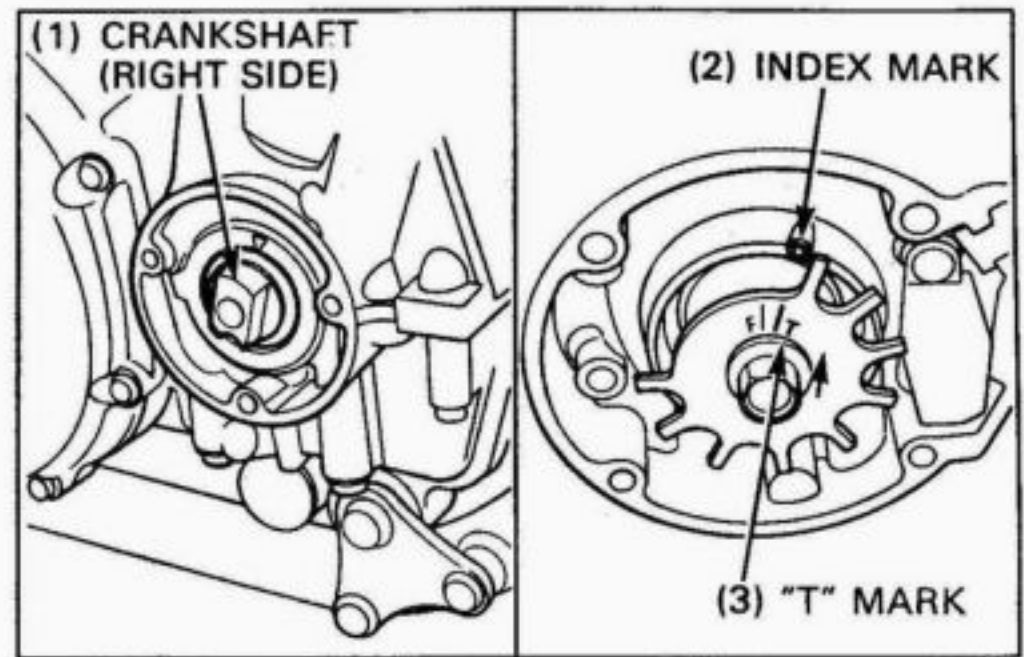

Coat the cylinder head journal surfaces of the camshaft with molybdenum disulfide oil.

Install the intake and exhaust camshafts and sprockets through the cam chain with the timing marks facing the right side.

Install the cam chain over the sprockets.

### NOTE

- The camshafts are identified by marks:  
 "IN": Intake camshaft  
 "EX": Exhaust camshaft

Rotate the camshafts so the No. 4 cylinder cam lobes face each other.

Install the two O-rings and dowel pins into the oil passage holes.

Install the eight dowel pins into the camshaft holder holes.

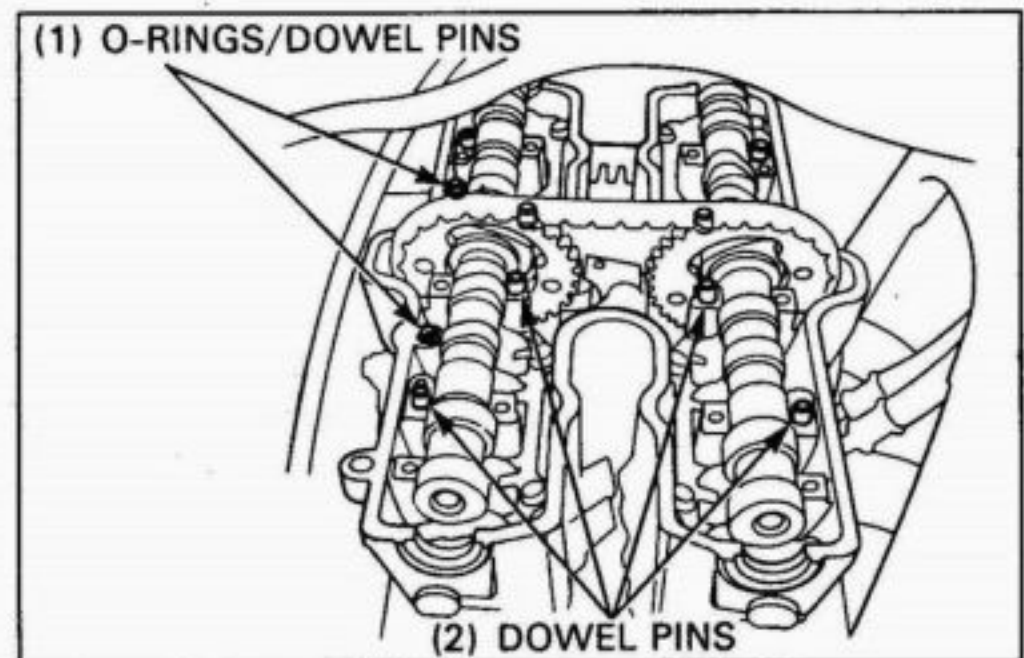
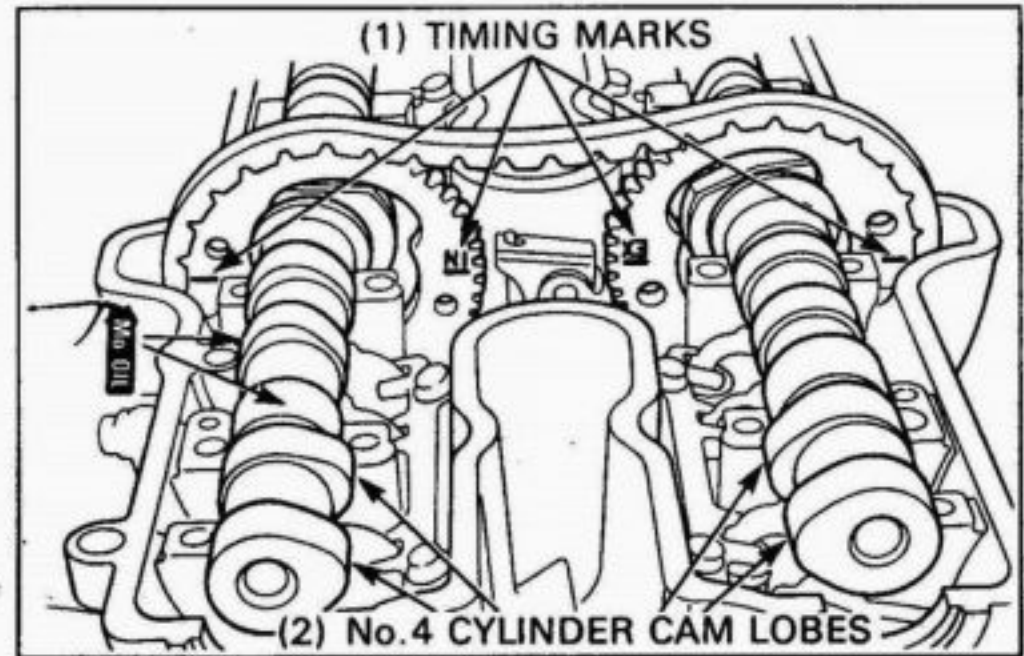

Install each camshaft holder in its original location.

### NOTE

- The holders are identified by marks:
- "IN R": Intake right
  - "IN L": Intake left
  - "EX R": Exhaust right
  - "EX L": Exhaust left

Temporarily tighten the camshaft holder bolts.

Align cam sprocket timing marks with the top of the cylinder head.

Install the cam sprockets on the camshaft flange and recheck that the timing marks align with the top of the cylinder head.

