

E - 10

Crankcase

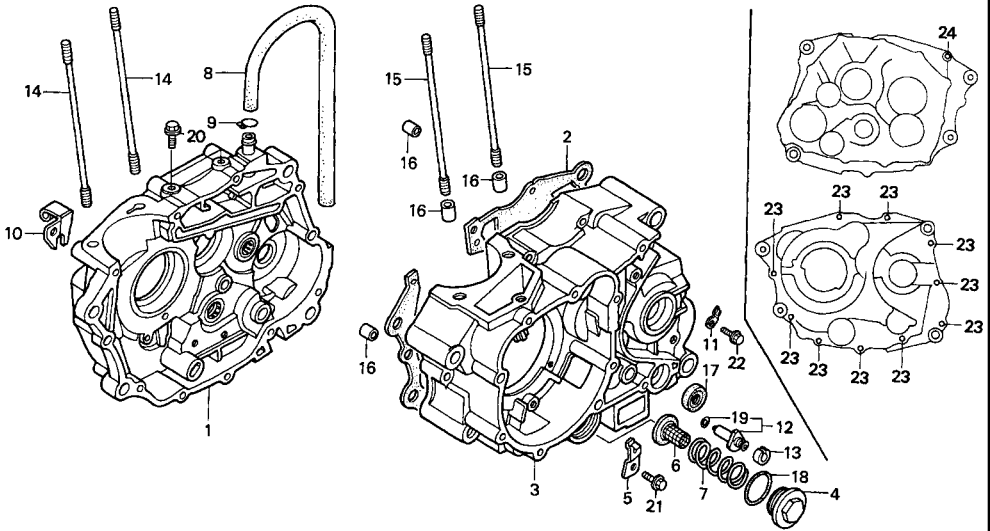

KEHG - GL156S

No.	Part Number	Description	Q'ty
1	11100-KCJ-711	CRANKCASE COMP, R	1
2	11191-KCJ-710	GASKET, CRANKCASE	1
3	11200-KCJ-710	CRANKCASE COMP., L	1
4	12361-383-000	CAP, TAPPET ADJUSTING HOLE	1
5	14513-KBB-900	PLATE, CAM CHAIN SETTING	1
6	15421-107-000	SCREEN, OIL FILTER	1
7	15426-107-000	SPRING, OIL FILTER SCREEN	1
8	15761-KCJ-710	TUBE, BREATHER	1
9	15772-292-010	CLIP, BREATHER TUBE	1
10	22838-437-000	HOLDER, CLUTCH WIRE	1
11	32976-KCT-690	CLAMPER, WIRE HARNESS	1
12	35750-GS3-003	CONTACT, NEUTRAL SWITCH	1
13	35752-KCT-690	SPACER, NEUTRAL SWITCH	1
14	90031-KFB-000	BOLT A, CYLINDER STUD	2
15	90032-107-010	BOLT B. CYLINDER STUD	2
16	90703-HC4-000	PIN, DOWEL, 10X14	4
17	91206-286-013H	OIL SEAL, 14X28X7	1
18	91303-KK3-830	O-RING, 35X3	1
19	91312-107-000	O-RING, 7X1.7	1
20	95701-06012-00	BOLT, FLANGE, 6X12	2