

Block No.

**E-7
CLUTCH**

2006 NSF100

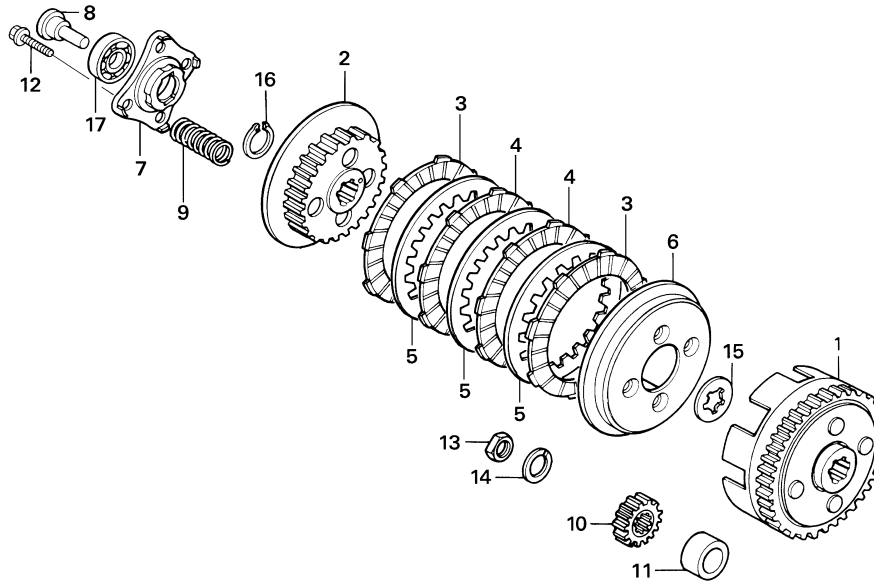

Ref. No.	Part No.	Description	Reqd. No.	Remarks
1	22100-436-000	OUTER COMP., CLUTCH (71T).....	1	
2	22121-KTK-000	CENTER, CLUTCH.....	1	
3	22201-GBF-B40	DISK, CLUTCH FRICTION	2	
4	22201-KPM-850	DISK, CLUTCH FRIC, 4X8X45	2	
5	22311-KN4-680	PLATE, CLUTCH.....	3	
6	22350-115-020	PLATE, CLUTCH PRESSURE	1	
7	22361-107-000	PLATE, CLUTCH LIFTER	1	
8	22366-115-000	PIN, CLUTCH LIFTER GUIDE	1	
9	22401-KN4-680	SPRING, CLUTCH	4	
10	23121-149-000	GEAR, PRIMARY DRIVE (16T)	1	
11	23122-436-000	COLLAR, PRIMARY DRIVE GEAR	1	
12	90050-357-000	BOLT, SPECIAL FLANGE, 6X22	4	
13	90201-KBP-900	NUT, SPECIAL, 14MM	1	
14	90408-MN5-000	WASHER, 14.2X23X2.6.....	1	
15	90462-115-010	WASHER B, SPLINE, 17MM.....	1	
16	94510-17000	CIRCLIP, EXTERNAL, 17MM	1	
17	96100-60010-00	BEARING, RADIAL BALL, 6001	1	