

MAJOR COMPONENTS

(Information you need to operate this motorcycle)

SUSPENSION

Front Suspension

Compression Damping:

To reduce (SOFT) :

Turn the adjuster counterclockwise toward SOFT for a light load and smooth road condition.

To increase (HARD) :

Turn the adjuster clockwise toward HARD for a firmer ride and rough road condition.

To adjust the adjuster to the standard position, proceed as follows :

1. Remove the cap (1) and turn the damping adjuster (2) clockwise until it will no longer turn (lightly seats). This is the full hard setting.
2. Turn the damping adjuster counterclockwise 10 clicks back from full hard. This is the standard position.
3. Make sure that both fork legs are adjusted to the same position.

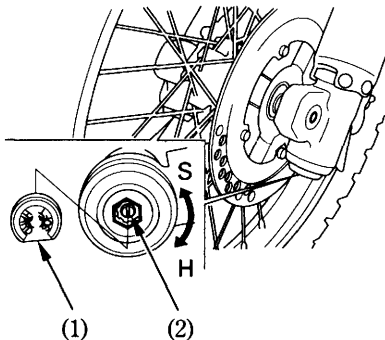

(1) Cap

(2) Damping adjuster