

# Engine Oil & Filter

---

2. Stop the engine, place an oil drain pan under the oil tank and crankcase. Remove the oil fill cap, the drain plug (1) and sealing washer (2) on the oil tank. Remove the drain plug (3) and sealing washer on the crankcase.

## UNDER ENGINE

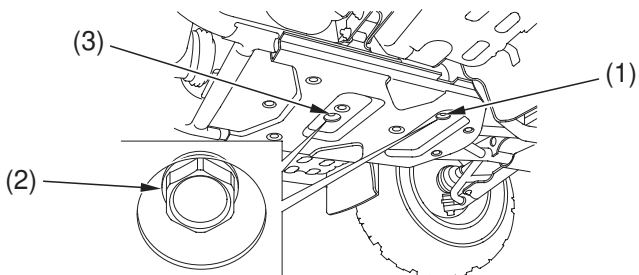

(1) drain plug (oil tank)

(2) sealing washer

(3) drain plug (crankcase)

## *Install a New Engine Oil Filter:*

3. Remove the engine guard (4) by removing the mount bolts A (5) and mount bolts B (6).

## UNDER ENGINE

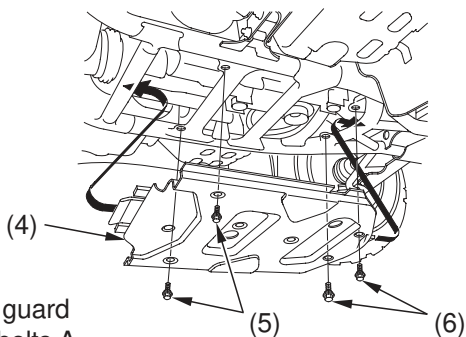

(4) engine guard

(5) mount bolts A

(6) mount bolts B