

Frame servicing

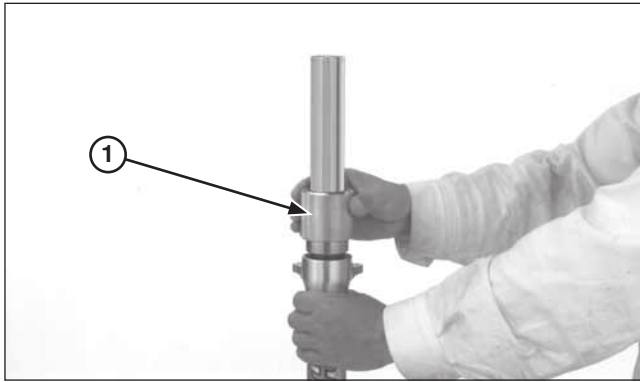

(1) FORK SEAL DRIVER

Using the special tool, drive the guide bushing and back-up ring until the stop ring groove is fully stuck in the fork slider base.

Install the oil seal (spring up) in the fork slider. Drive the oil seal using the special tool, performing a constant pressure until stops in back-up ring.

Tool:
Fork seal driver 07947-4630100

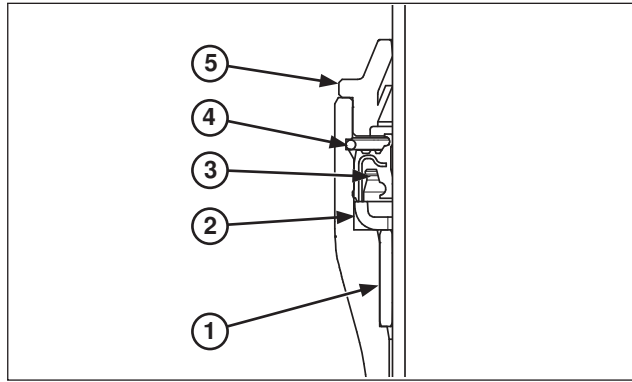

(1) GUIDE BUSHING (4) STOP RING
(2) BUCK-UP RING (5) DUST SEAL
(3) OIL SEAL

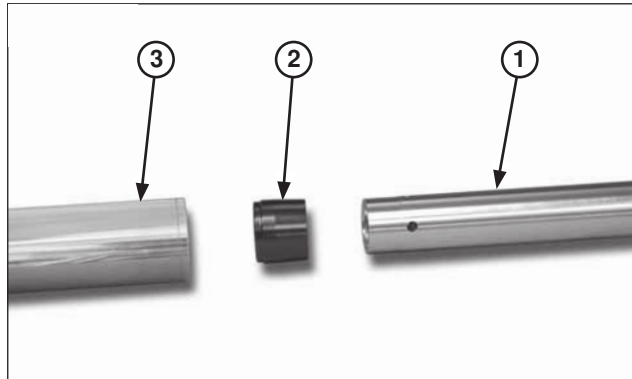

(1) FORK DAMPER
(2) CENTERING PLATE
(3) FORK TUBE

Install the stop ring into the slider groove securely.
Install the dust seal.

Install the centering plate and fork damper into the fork tube.

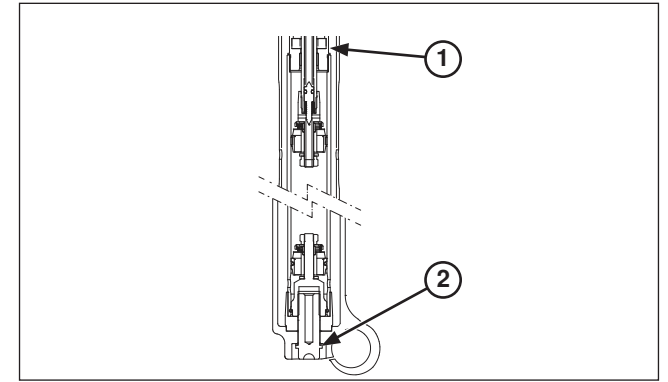

(1) FORK DAMPER
(2) RIGHT FORK CENTER BOLT

Hold the axle holder in a vise protected with a piece of woods or soft jaws to avoid damage.
Do not overtighten the vise.

Install the right fork center bolt with a new sealing washer.

Tighten the right fork center bolt to the specified torque.

Torque: 23,5-25,5 N•m (2,39-2,59 kgf•m)