

(1) BANJO BOLT
(2) SEALING WASHER

Fuel Line Inspection

Fuel Pressure Inspection

WARNING

Gasoline is highly flammable and is explosive. You can be burned or seriously injured.

- Stop engine and keep heat, sparks, and flame away.
- Refuel only outdoors.
- Wipe up spills immediately.

NOTICE

- Before disconnecting the fuel hoses, release the fuel pressure by loosening the fuel feed hose banjo bolt at the injector holder.
- Always replace the sealing washers when the fuel hose banjo bolt is removed or loosened.

Remove the seat, front covers, side covers and the seat-rear fender assy.

Cover the fuel feed hose banjo bolt with a rag or shop towel. Slowly loosen the banjo bolt and catch the remaining fuel using a approved gasoline container.

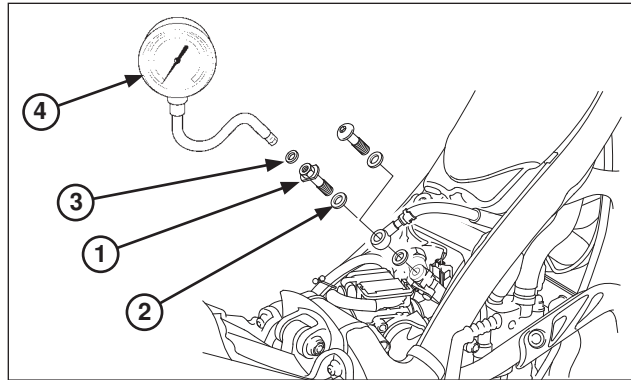

(1) MANOMETER ADAPTER, 12 MM
(2) SEALING WASHER, 12 MM
(3) SEALING WASHER, 6 MM
(4) F. PRESSURE GAUGE

Remove the fuel feed hose banjo bolt and attach the fuel pressure gauge with the following Montesa Genuine parts.

Manometer adapter, 12 mm
part No. 90008-PP4-E02
Sealing washer, 12 mm
part No. 90428-PD6-003
Sealing washer, 6 mm
part No. 90430-PD6-003

Tool:
Fuel pressure gauge 07406-0040003 or
 07406-0040002

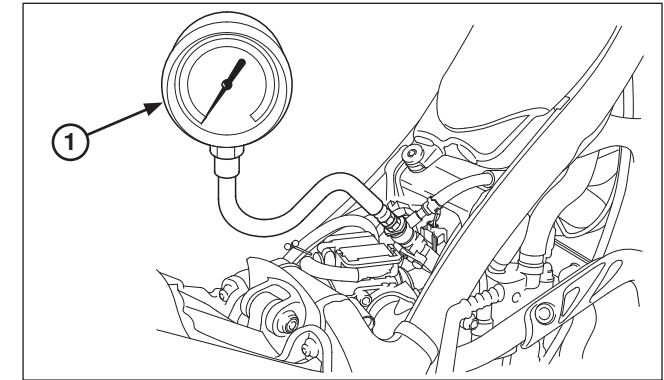

(1) FUEL PRESSURE GAUGE

Start the engine.
Read the fuel pressure at idle speed.

Idle Speed: 1,800 ± 100 min-1 (rpm)
Standard: 230 kPa - 320 kPa
(2,34 kgf/cm² - 3,26 kgf/cm²)
(33 psi - 46 psi)

If the fuel pressure is higher than specified, inspect the following:

- Fuel pump (page 3-7)

If the fuel pressure is lower than specified, inspect the following:

- Fuel line leaking
- Clogged fuel filter
- Fuel pump (page 3-7)