

(1) FUEL FEED HOSE

### Fuel Line

Remove the seat, front covers, side covers and the seat-rear fender assy.

Check the fuel feed hose for cracks, deterioration or leakage.

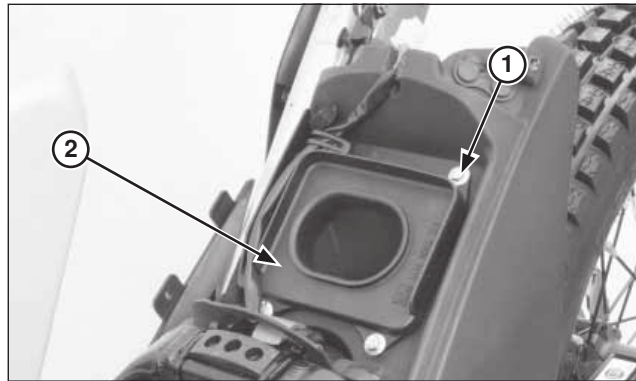

(1) BOLTS  
(2) AIR CLEANER HOUSING COVER

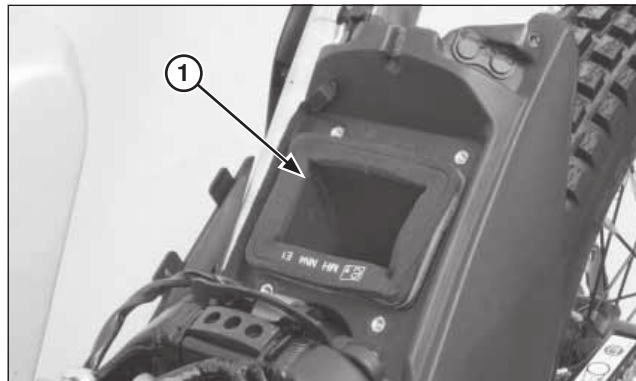

(1) AIR CLEANER ELEMENT

### Air Cleaner

Remove the four bolts and air cleaner housing cover.

Remove the air cleaner element assembly from the air cleaner housing.

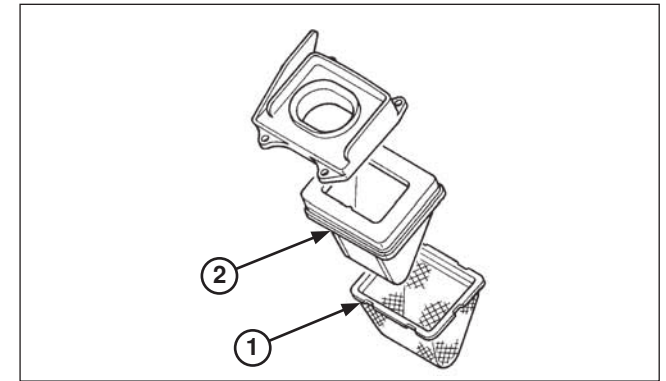

(1) FLAME TRAP  
(2) AIR CLEANER ELEMENT

Remove the flame trap from the air cleaner element. Check the flame trap for damage, replace if necessary.

Thoroughly wash the element in clean non-flammable cleaning solvent, then wash in a solution of hot water and dish-washing liquid soap.

Apply engine oil to the element, and squeeze out excess oil.

Clean the inside of the air cleaner housing.

### WARNING

**Never use gasoline or low flash point solvents for cleaning the air cleaner element. A fire or explosion could result. Soak the element in engine oil and squeeze out the excess.**

### NOTICE

*Do not twist the element to squeeze out the excess. Failure to follow this precaution can result in a damaged element.*

Installation is in the reverse order of removal.