

Subframe

- Connect the starter motor terminal (3) to the starter relay switch (4).
Install and tighten the starter motor terminal bolt (5) to the specified torque:
5.2 lbf-ft (7.0 N·m, 0.7 kgf-m)
Connect the starter relay switch connector (6) and then install the starter relay switch cover (7).
Install the starter relay switch.
Install and tighten the starter relay switch stay bolt (8) to the specified torque:
7 lbf-ft (10 N·m, 1.0 kgf-m)
Install the plastic wire band (9).

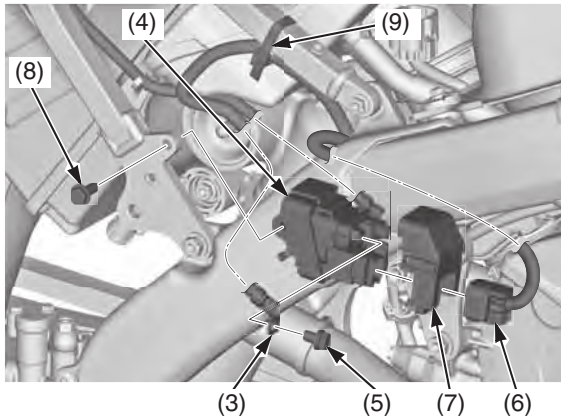

- (3) starter motor terminal
- (4) starter relay switch
- (5) starter motor terminal bolt
- (6) starter relay switch connector
- (7) starter relay switch cover
- (8) starter relay switch stay bolt
- (9) plastic wire band

- Connect the negative (-) terminal (10) to the battery (11).
Tighten the negative (-) terminal bolt (12) to the specified torque:
1.5 lbf-ft (2.0 N·m, 0.2 kgf-m)

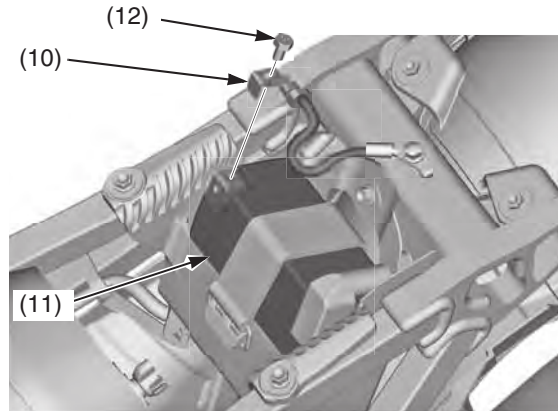

- (10) negative (-) terminal
- (11) battery
- (12) negative (-) terminal bolt

- Connect the air cleaner box (13) to the air cleaner connecting tube (14) and tighten the air cleaner connecting tube clamp screw (15) so the distance between the clamp ends is 0.30 ± 0.06 in (7.5 ± 1.5 mm).
- Connect the breather tube (16) and IAT sensor connector (17).

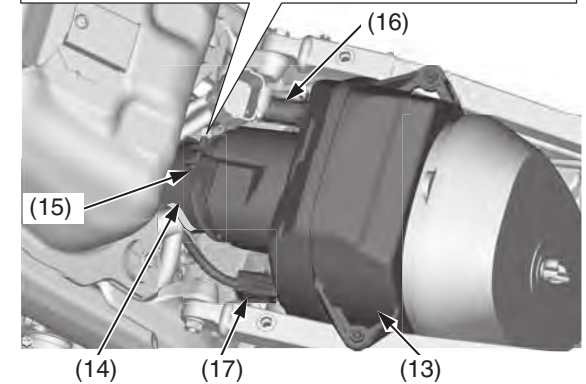
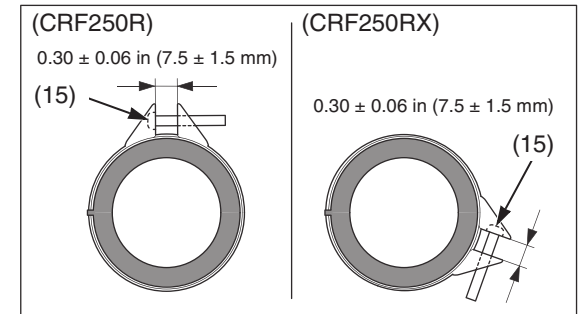

- (13) air cleaner box
- (14) air cleaner connecting tube
- (15) air cleaner connecting tube clamp screw
- (16) breather tube
- (17) IAT sensor connector