

Refer to *Important Safety Precautions* on page 23.

Steering Head Bearing Inspection

1. With your CRF on an optional workstand or equivalent support (front wheel elevated), turn the handlebar to the right and left to check for roughness in the steering head bearings.

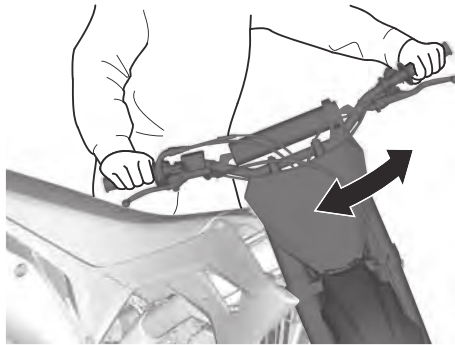

2. Stand in front of your CRF, grab the fork (at the axle), look at the steering head, and push the fork in and out (toward the engine) to check for play in the steering head bearings.

If any roughness or play is felt, but you do not see any movement in the steering head, the fork bushings may be worn.

Refer to an official Honda Service Manual for replacement or adjustment procedures, or see your dealer.



Handlebar Inspection

1. Check the handlebar (1) for bends or cracks.
2. Check that the handlebar has not moved from its original position where the end of the right handlebar holders (2) is aligned with the paint mark (3).
3. Check the torque of the handlebar upper holder bolts (4):
16 lbf·ft (22 N·m, 2.2 kgf·m)
Tighten the front bolts first.

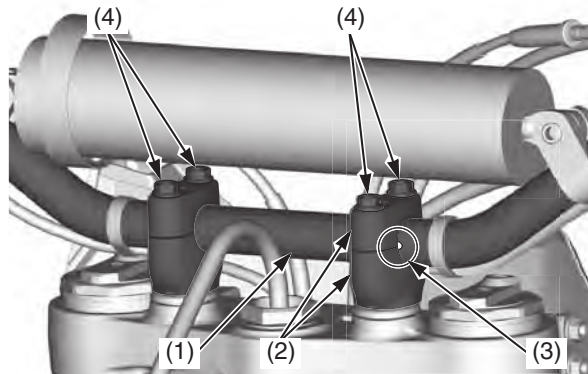

- (1) handlebar
- (2) right handlebar holders
- (3) paint mark
- (4) handlebar upper holder bolts

Control Cables

Periodically, disconnect the throttle and clutch cables at their upper ends. Thoroughly lubricate the cable pivot points with a commercially available cable lubricant. If the clutch lever and throttle operation is not smooth, replace the cable. Be sure the throttle returns freely from fully open to fully closed automatically, in all steering positions.