

9. Check for interference between the frame and tank, and adjust the cushion rubbers (17) on the both sides of the frame if necessary.

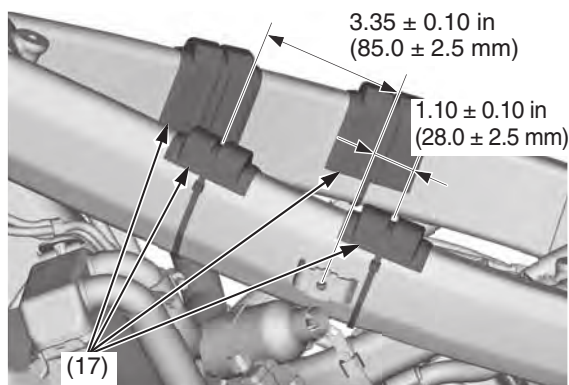

(17) cushion rubbers

NOTICE

*Do not ride your CRF in state which the cushion rubbers have been removed.
It may cause the fuel tank cracking.*

Installation

1. Install the fuel tank (1) on the frame.
2. Install the washers (2), fuel tank A bolt (3) and B bolts (4), and then tighten the fuel tank A bolt and B bolts to the specified torque:
7 lbf·ft (10 N·m, 1.0 kgf·m)

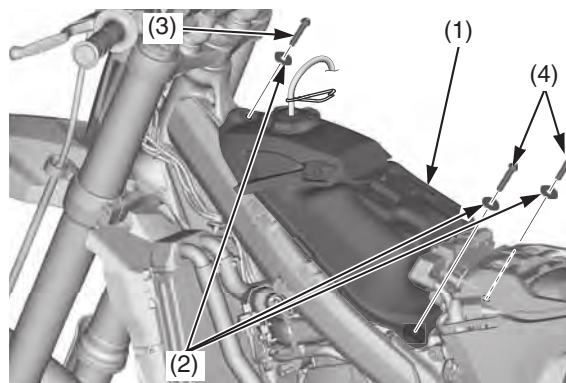

(1) fuel tank
(2) washers

(3) fuel tank A bolt
(4) fuel tank B bolts

3. Put the breather tube (5) in the steering stem nut (6).
4. Remove the hose clamp (7) from the breather tube.

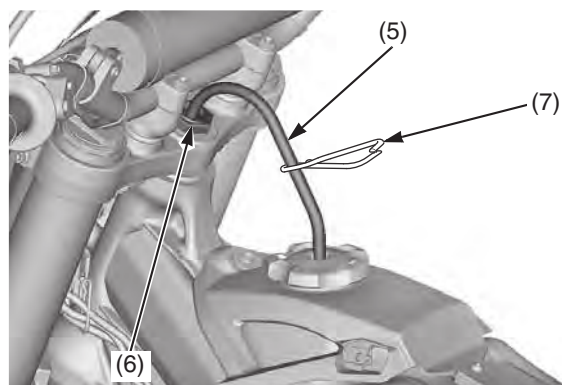

(5) breather tube
(6) steering stem nut

(7) hose clamp

5. Connect the overflow hose (8) to the clamp (9).

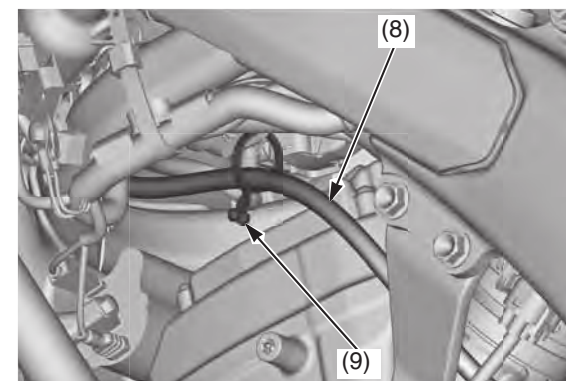

(8) overflow hose
(9) clamp

(cont'd)