

8. Hold the connector with one hand and squeeze the retainer tabs (9) with the other hand to remove the locking pawls (10) from the connector grooves.

Pull the connector off, then remove the retainer.

- Use a shop towel to absorb the remaining fuel in the fuel feed hose.
- Be careful not to damage the hose or other parts.
- Do not use tools.
- If the connector does not move, keep the retainer tabs pressed down, and alternately pull and push the connector until it comes off easily.

⚠ WARNING

Gasoline is highly flammable and explosive. You can be burned or seriously injured when handling fuel.

- Stop the engine and keep heat, sparks and flame away.
- Handle fuel only outdoors.
- Wipe up spills immediately.

Injector side:

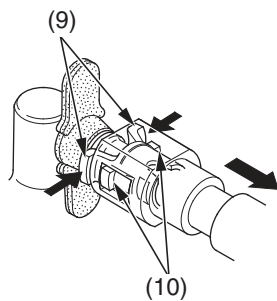

Fuel Pump side:

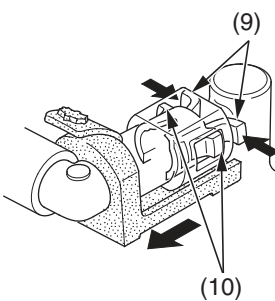

(9) retainer tabs
(10) locking pawls

9. To prevent damage and keep foreign matter out, cover the disconnected connectors (11) and fuel joints (12) with plastic bags (13).

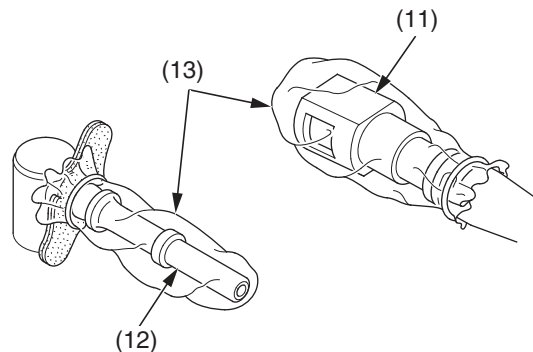

(11) disconnected connectors
(12) fuel joints
(13) plastic bags

Connection

1. Insert a new retainer (1) into the connector (2) by aligning its locking pawls (3) with the connector grooves (4).

- Always replace the retainer and joint rubber of the quick connect fitting when the fuel feed hose is disconnected.
- If the joint rubber is damaged or cut, replace it with a new one.
- Do not bend or twist the fuel feed hose.
- If any retainer needs replacing, use the same manufacturer's retainer as the one being removed (Various manufactures produce different types of retainers).

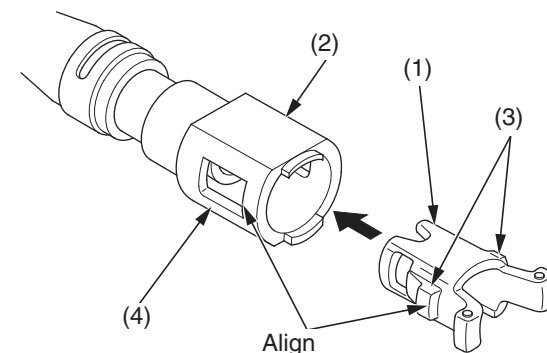

(1) retainer (new)
(2) connector

(3) locking pawls
(4) connector grooves

(cont'd)