

Valve Clearance

13. Remove the tensioner stopper (23) from the cam chain tensioner lifter.

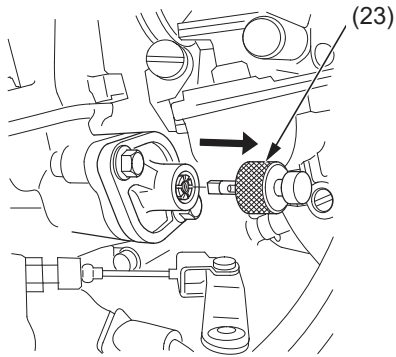

(23) tensioner stopper

14. Install a new sealing washer (24) and tighten the cam chain tensioner lifter cover bolt (25).

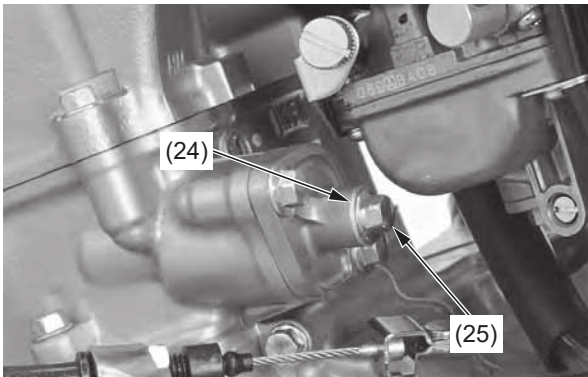

(24) sealing washer
(25) cam chain tensioner lifter cover bolt

15. Rotate the primary drive gear bolt (crankshaft) clockwise two turns and align the punch mark (2) with the index mark (3).

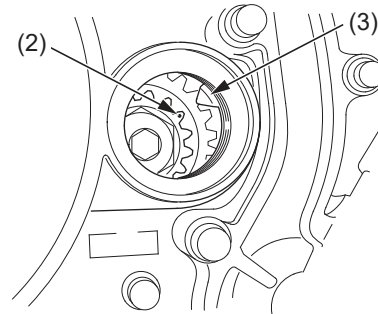

(2) punch mark
(3) index mark

16. Measure the intake valve clearance and exhaust valve clearance by inserting a feeler gauge (26).

Valve Clearance:

IN: 0.006 ± 0.001 in (0.16 ± 0.03 mm)
EX: 0.010 ± 0.001 in (0.26 ± 0.03 mm)

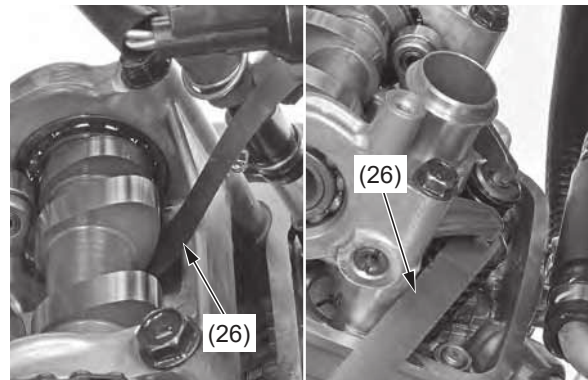

(26) feeler gauge

17. Coat a new O-ring (27) with oil and install it onto the crankshaft hole cap (28).

Apply grease to the crankshaft hole cap threads.

Install and tighten the crankshaft hole cap to the specified torque:

11 lbf-ft (15 N-m, 1.5 kgf-m)

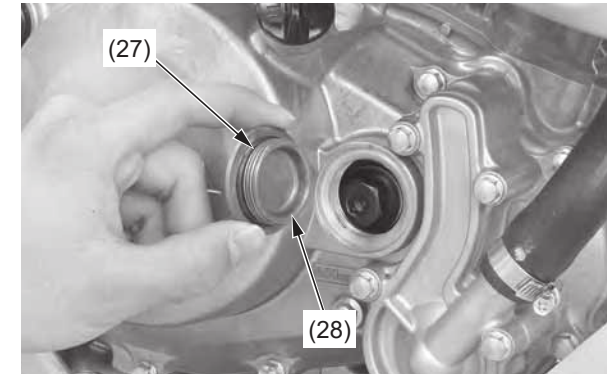

(27) O-ring
(28) crankshaft hole cap