

Carburetor Adjustments & Tuning Tips

6. Remove the accelerator pump cover screws (10) and accelerator pump cover (11).

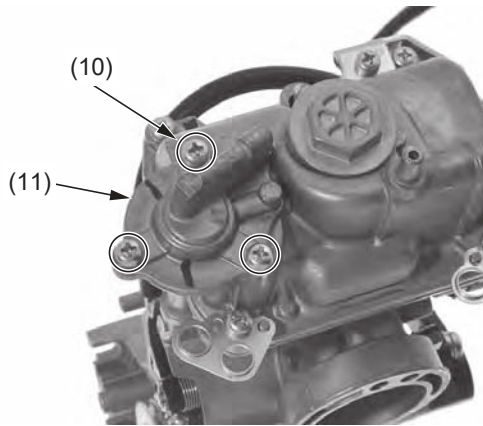

(10) accelerator pump cover screws
(11) accelerator pump cover

7. Remove the U-ring (12), O-ring (13), spring (14) and diaphragm (15).
Clean the diaphragm.
When installing the U-ring into the accelerator pump cover (11) make sure the U-ring flatside faces the accelerator pump cover, away from the float bowl (16).

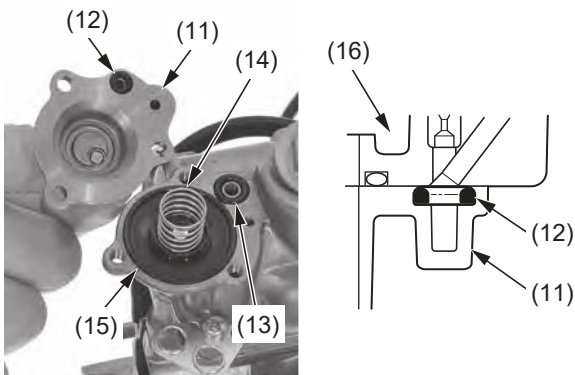

(11) accelerator pump cover
(12) U-ring
(13) O-ring

(14) spring
(15) diaphragm
(16) float bowl

8. Remove the holder screw (17), throttle stop screw holder (18), float bowl screws (19), hose guides (20), float bowl (16) and O-ring (21).

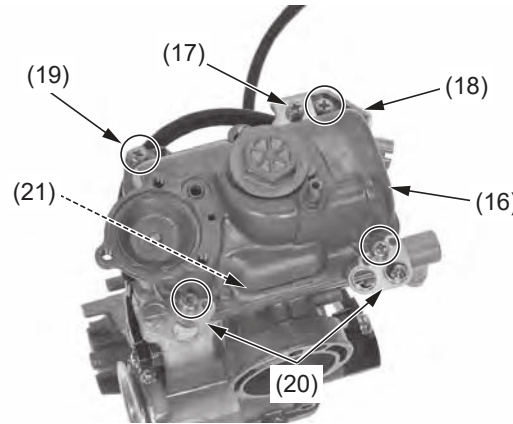

(16) float bowl
(17) holder screw
(18) throttle stop screw holder
(19) float bowl screws
(20) hose guides
(21) O-ring

9. Remove the pump rod (22).
Clean the pump rod and rod passage (23).
Install the pump rod by pushing the rod forcibly into the link lever (24) until it snaps into place.

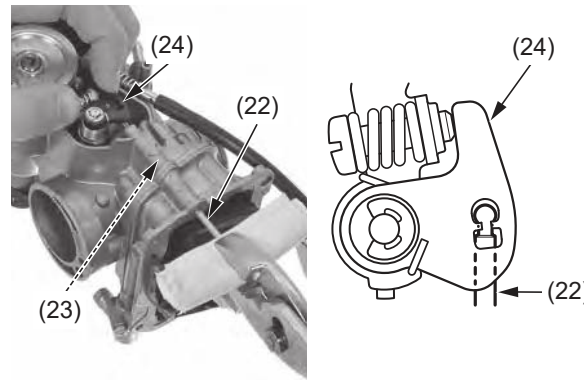

(22) pump rod
(23) rod passage

(24) link lever

10. Measure the float level (25) with the float level gauge (26) while the float tab is just contacting the float valve and the carburetor intake (27) is facing up. The float level should be 0.28 in (7.0 mm). If the float level is out of specification, adjust it by bending the float tab carefully.

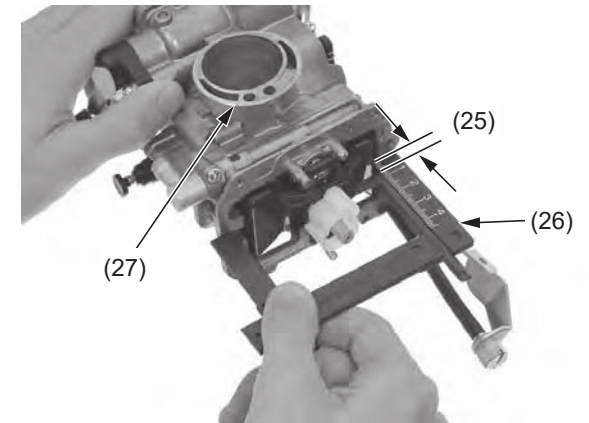

(25) float level
(26) float level gauge
(27) carburetor intake

11. Remove the leak jet (28) from the float bowl (16). Clean the leak jet.

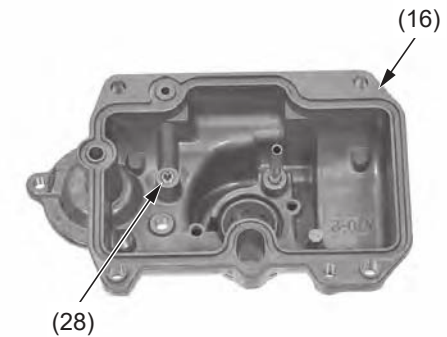

(16) float bowl

(28) leak jet