

Valve Clearance

LEFT SIDE

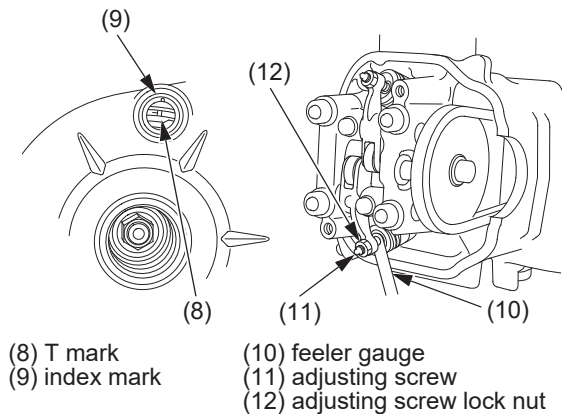

4. Rotate the generator flywheel counterclockwise until the T mark (8) on the flywheel lines up with the index mark (9) on the left crankcase cover. In this position, the piston may either be on the compression or exhaust stroke.

The adjustment must be made when the piston is at the top of the compression stroke when both the intake and exhaust valves are closed. This condition can be determined by moving the rocker arms. If they are free, it is an indication that the valves are closed and that the piston is on the compression stroke. If they are tight and the valves are open, rotate the flywheel 360° and realign the T mark to the index mark.

5. Check the clearance of both valves by inserting a feeler gauge (10) between the adjusting screw (11) and the valve stem. Clearance should be:
Intake: 0.004 in (0.10 mm)
Exhaust: 0.004 in (0.10 mm)

(cont'd)