

- (1) BOOT
- (2) SNAP RING
- (3) PISTON ASSEMBLY
- (4) SPRING
- (5) OIL SEAL
- (6) CIRCLIP

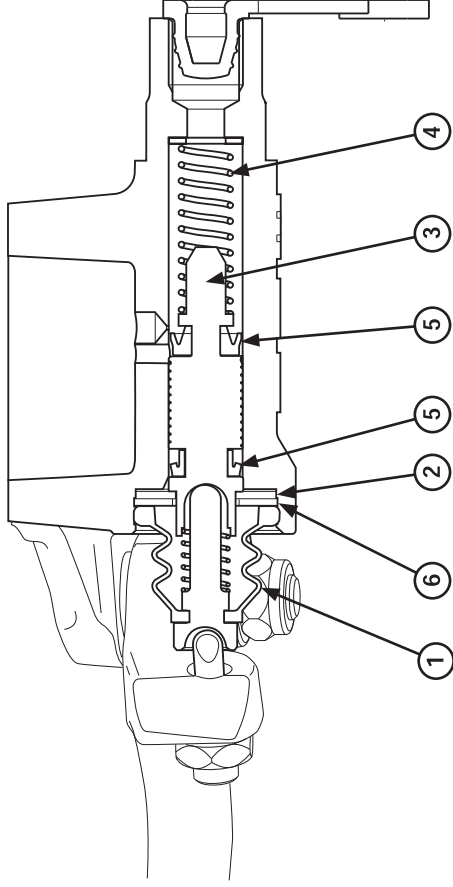

Disassembly/Assembly

NOTICE

- *Keep the master cylinder piston, oil seals, spring and snap ring as a set; don't substitute individual parts.*
- *When installing the oil seals, do not allow the lips to turn inside out and be certain the snap ring is firmly seating in the groove.*

Remove the snap ring and disassemble the master cylinder.

Inspection

Check the following items (page 2-3):

- Master cylinder and piston for scoring, scratches or other damage
- Master piston O.D. and master cylinder I.D.

Installation

Installation is in the reverse order of removal.

Torque:

Brake hose oil bolt: 14 N•m (1.4 kgf•m, 10.3 lbf•ft)
Master cylinder holder bolt: 5.5 N•m (0.56 kgf•m, 4.1 lbf•ft)

Bleed the air from the clutch system.