

- (1) FORK TUBE
- (2) CYLINDER ASSY
- (3) TAPERED BUSHING
- (4) FORK SLIDER

Remove the tapered bushing from the cilinder assy.

NOTICE

Be careful not to damage the tapered bushing.

Remove the cilinder assy from the fork tube.

Remove the following items using the same procedure as the right fork disassembly (page 5-3):

- Oil seal
- Back-up ring
- Guide bushing
- Fork tube bushing

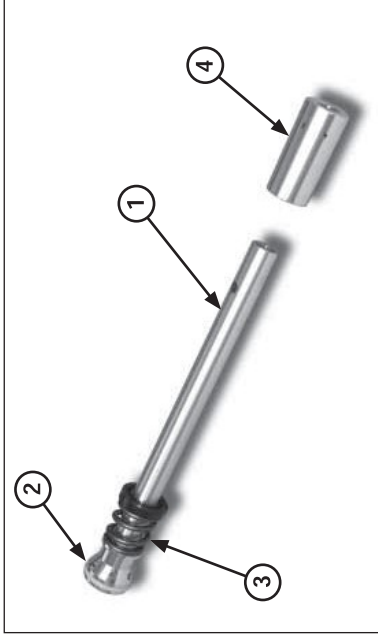

- (1) CILINDER ASSY
- (2) PISTON RING
- (3) REBOUND SPRING
- (4) TAPERED BUSHING

Left Fork Inspection

Check the following items (page 2-4):

- Inside fork slider for damage or deformation
- Fork tube runout
- Fork spring free length
- Fork tube for score marks, scratches and excessive wear
- Bushing/back-up ring (page 5-5)
- Fork piston ring for wear or damage
- Tapered bushing for damage
- Rebound spring for fatigue or other damage

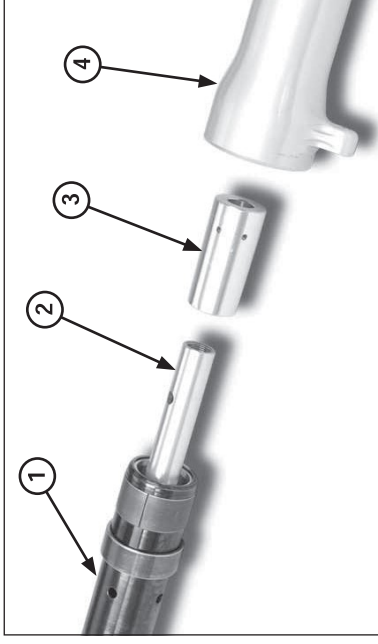

- (1) FORK TUBE
- (2) CILINDER ASSY
- (3) TAPERED BUSHING
- (4) FORK SLIDER

Left Fork Assembly

Clean the parts thoroughly with non-flammable or high flush point solvent before assembly.

Apply fork fluid to the piston ring.

Install the cilinder assy into the fork tube.

Install the tapered bushing on the end of the cilinder assy.

NOTICE

The tapered bushing is easy to scratched or deformed. Take care not to damage it when assembling it.