

### Crankshaft/Transmission Inspection

Measure the crankshaft runout. Support the crankshaft at point "A" and "B", and then measure the runout at the points "C" and "D".

**Service limit:** C: 0.05 mm (0.002 in)  
D: 0.03 mm (0.001 in)

Measure the connecting rod big end side clearance and big end axial/radial play (specification; page 2-3).

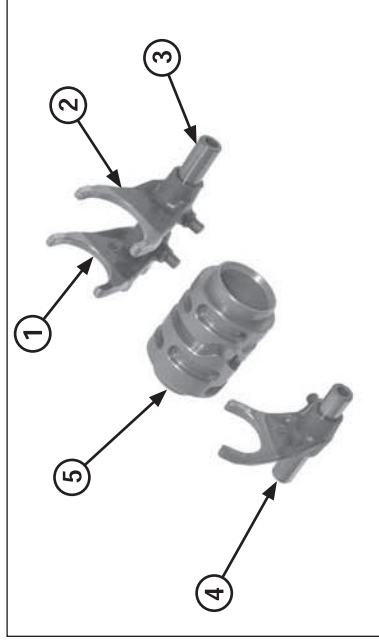
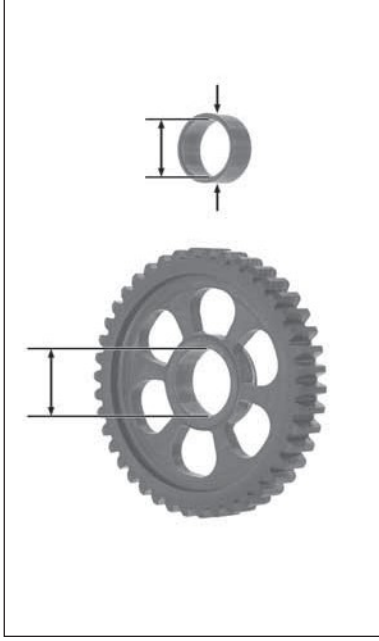

- (1) RIGHT SHIFT FORK
- (2) LEFT SHIFT FORK
- (3) RIGHT/LEFT SHIFT FORK SHAFT
- (4) CENTER SHIFT FORK/SHAFT
- (5) SHIFT DRUM

Inspect each part for wear or damage. Check the following items (specifications; page 2-1).

- Spinning gear I.D.
- Bushing I.D. and O.D.
- Mainshaft and countershaft O.D.
- Shift fork I.D. and claw thickness
- Shift fork shaft O.D.
- Shift drum O.D.

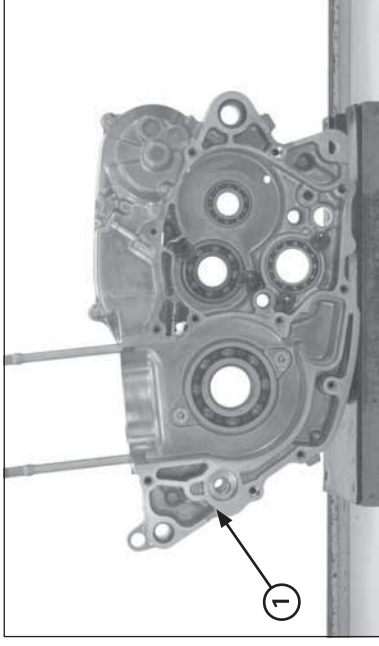

(1) RIGHT CRANKCASE

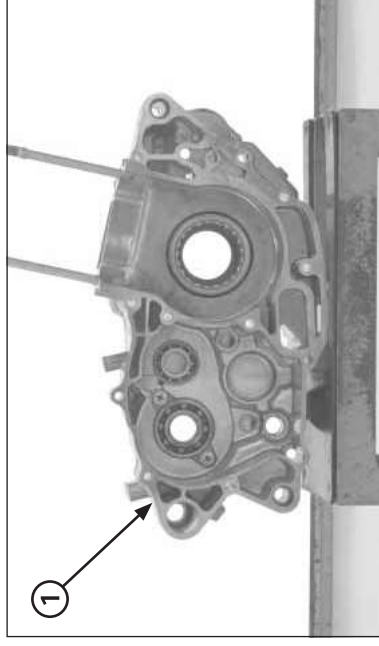

(1) LEFT CRANKCASE

### Crankcase Bearing Replacement

Remove the oil seals and bearing set plates. Drive out the bearing using the special tools (Tools; page 2-7).

Install the new bearing as shown in the illustration using the special tools.