

**Torque Values**

**Standard**

Item	Torque N·m (kgf·m / lbf·ft)
5 mm bolt and nut	5 (0.52 / 3.5)
6 mm bolt and nut	10 (1.0 / 7)
8 mm bolt and nut	22 (2.2 / 16)
10 mm bolt and nut	33 (3.4 / 25)
12 mm bolt and nut	53 (5.4 / 40)
5 mm screw	4 (0.42 / 3)
6 mm screw and flange bolt (SH type)	9 (0.9 / 7)
6 mm flange bolt and nut	12 (1.2 / 9)
8 mm flange bolt and nut	26 (2.7 / 20)
10 mm flange bolt and nut	38 (3.9 / 29)

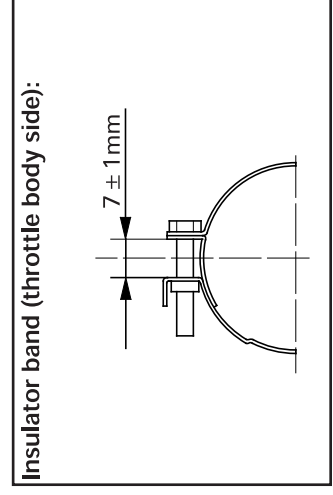
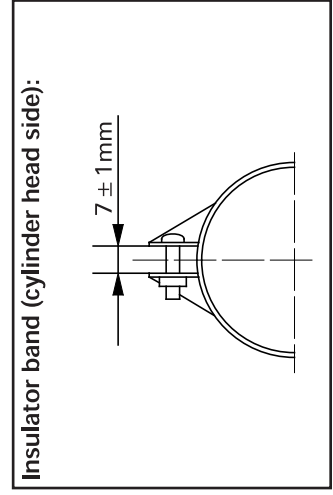
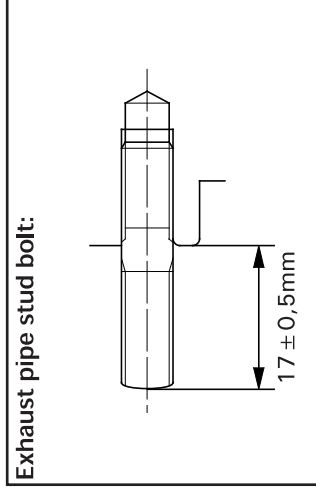
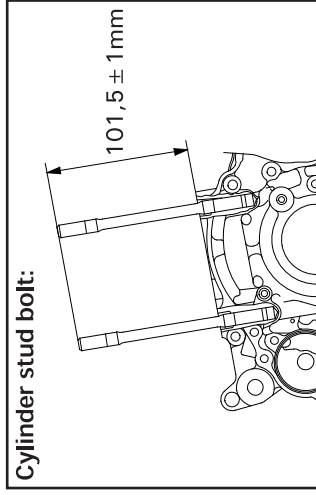

**Engine**

Item	Q'ty	Thread Dia. (mm)	Torque N·m (kgf·m / lbf·ft)	Remarks
Transmission oil drain bolt	1	8	22 (2.2 / 16)	Note 1
Engine oil drain bolt	1	8	22 (2.2 / 16)	Note 1
Right crankcase cover joint pipe	1	18	18 (1.8 / 13)	Note 2
Timing hole cap	1	14	7 (0.7 / 5.1)	Note 3
Bearing set plate socket bolt	4	6	9.8 (1.0 / 7)	Note 4
Bearing set plate screw	2	6	12 (1.2 / 9)	Note 4
Bearing set plate flat screw	2	6	9.8 (1.0 / 7)	Note 4
Cylinder head sealing bolt	1	12	32 (3.3 / 24)	Note 4
Cylinder head mounting nut	2	9	39 (4.0 / 29)	Note 1
Cylinder head joint pipe	1	18	18 (1.8 / 13)	Note 2
Vacuum port joint	1	5	2.5 (0.25 / 1.8)	
Primary drive gear special bolt	1	12	108 (11.0 / 80)	Note 1
Flywheel nut	1	18	167 (17.0 / 123)	Note 1
Cam chain tensioner bolt	1	6	12 (1.2 / 9)	Note 4
Valve clearance adjusting nut	4	6	14 (1.4 / 10)	Note 1
Injector holder socket bolt	2	6	9.8 (1.0 / 7)	
Fuel hose banjo bolt (holder side)	1	18	24 (2.4 / 17.7)	
Water pump impeller	1	7	12 (1.2 / 9)	
Clutch oil bleeder screw	1	8	6 (0.6 / 4.3)	
Clutch spring bolt	6	6	12 (1.2 / 9)	
Clutch center lock nut	1	18	69 (7.0 / 51)	Note 1
Drive sprocket UBS bolt	1	8	31 (3.2 / 23)	
Shift drum center special bolt	1	8	22 (2.2 / 16)	Note 4
Shift drum stopper arm bolt	1	6	12 (1.2 / 9)	
Shift return spring pin	1	8	22 (2.2 / 16)	
Ignition pulse generator bolt	2	5	5.4 (0.55 / 4.0)	Note 4
Stator mounting bolt	3	5	5.4 (0.55 / 4.0)	Note 4
Spark plug	1	10	16 (1.6 / 12)	Note 2

- Notes:
1. Apply clean engine oil to the threads and seating surface.
  2. Apply sealant to the threads.
  3. Apply grease to the threads.
  4. Apply a locking agent to the threads.