

## Frame servicing

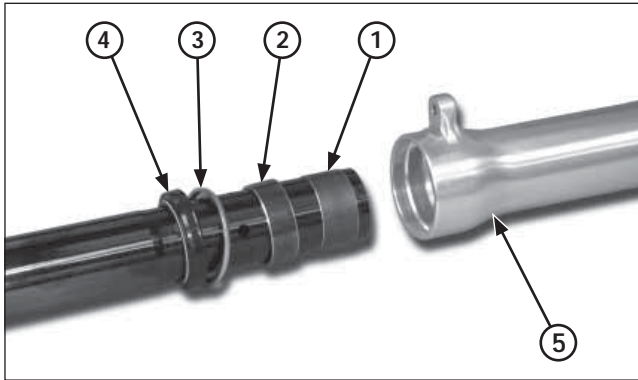

- (1) FORK TUBE BUSHING (4) OIL SEAL  
 (2) GUIDE BUSHING (5) FORK SLIDER  
 (3) BACK-UP RING

### Right Fork Assembly

Clean the parts thoroughly with non-flammable or high flash point solvent before assembly.

Install the following to the fork tube:

- Fork tube bushing
- Guide bushing
- Back-up ring

Coat the guide and fork tube bushings with recommended fork fluid.

Install the fork tube assembly into the fork slider.

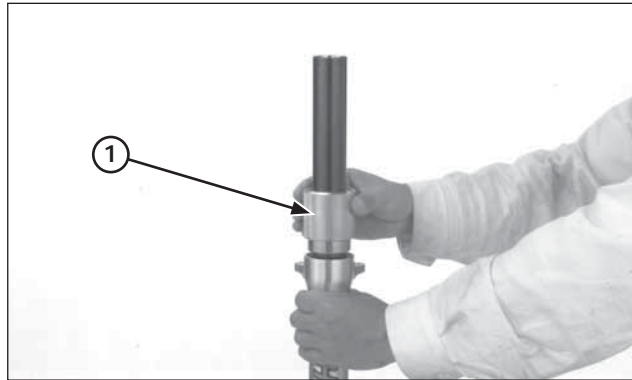

- (1) FORK SEAL DRIVER

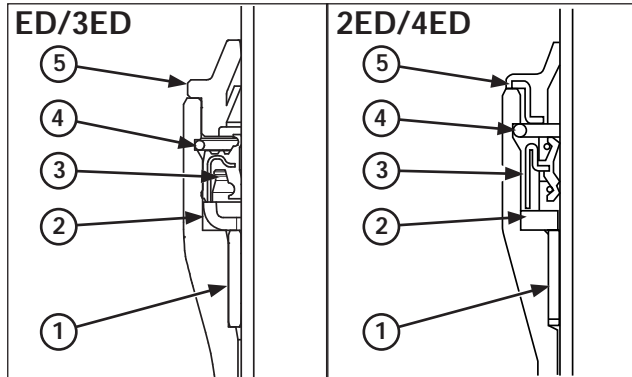

- (1) GUIDE BUSHING (4) STOP RING  
 (2) BUCK-UP RING (5) DUST SEAL  
 (3) OIL SEAL

Using the special tool, drive the guide bushing and backup ring until the stop ring groove is fully stuck in the fork slider base.

Install the oil seal (spring up) in the fork slider. Drive the oil seal using the special tool, performing a constant pressure until stops in back-up ring.

**Tool:**  
 Fork seal driver

07947-4630100

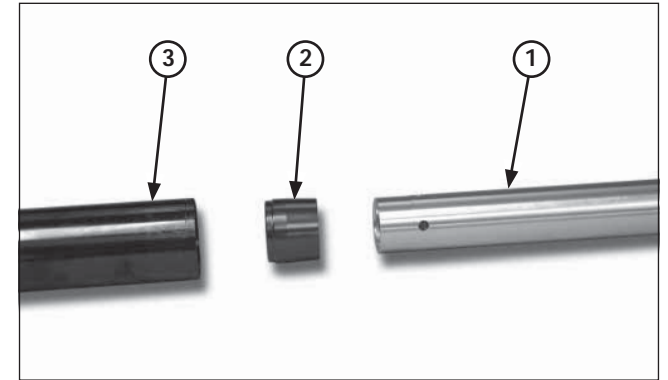

- (1) FORK DAMPER ASSEMBLY  
 (2) CENTERING PLATE  
 (3) FORK TUBE

Install the stop ring into the slider groove securely.  
 Install the dust seal.

Install the centering plate and fork damper into the fork tube.