

- (1) OIL BOLT
- (2) BRAKE HOSE
- (3) MASTER CYLINDER

Rear master cylinder

Removal/Installation

NOTICE

- *Avoid spilling brake fluid on painted, plastic or rubber parts. Place a shop rag over these parts whenever the system is serviced.*
- *When removing the brake hose bolt, cover the end of the hoses to prevent contamination. Secure the hoses to prevent fluid from leaking out.*

Drain the brake fluid from the hydraulic system into a suitable container.

Remove the air cleaner housing.
Remove the exhaust muffler.
Remove the reservoir tank from the bracket.

Remove the brake hose oil bolt and disconnect the brake hose eyelet joint.

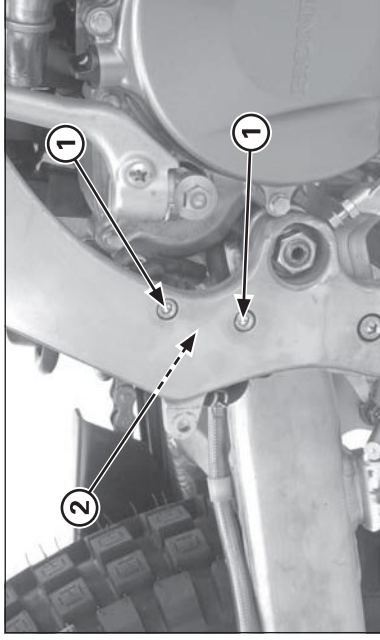

- (1) BOLTS
- (2) MASTER CYLINDER

Remove the mounting bolts and master cylinder.

Installation

Installation is in the reverse order of removal.

Connect the brake hose eyelet joint with two new sealing washers, then tighten the oil bolt.

Torque:

Brake hose oil bolt: 27 N·m (2.8 kgf·m, 20 lbf·ft)

Bleed the air from the rear brake system.

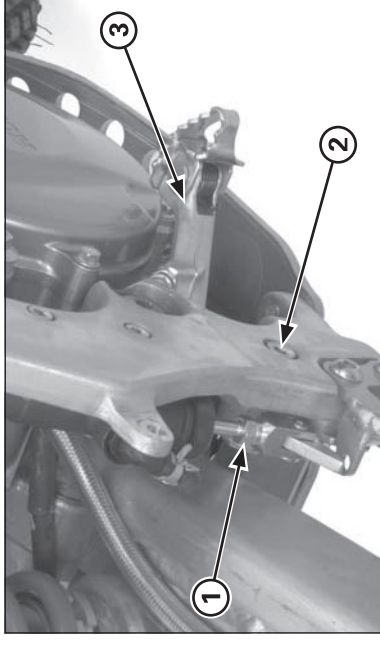

- (1) NUT
- (2) BOLT
- (3) BRAKE PEDAL

Brake pedal

Removal

Remove the brake pedal pivot nut and bolt.
Remove the brake pedal and collar.