

Frame servicing

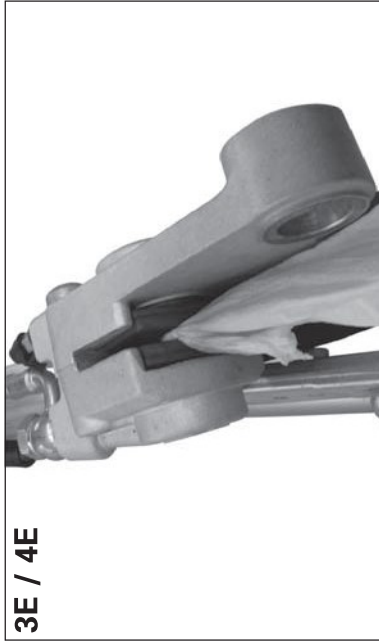

3E / 4E

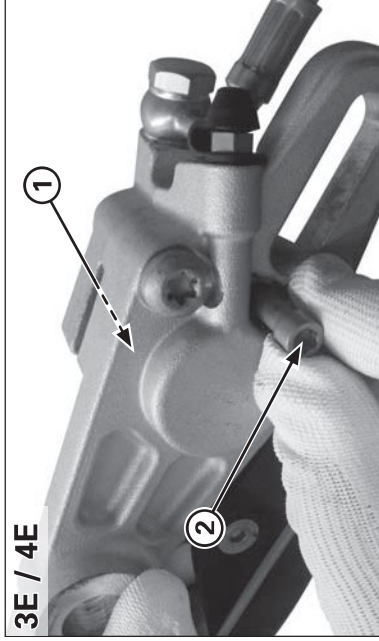

3E / 4E

- (1) BRAKE PADS
- (2) PAD PIN

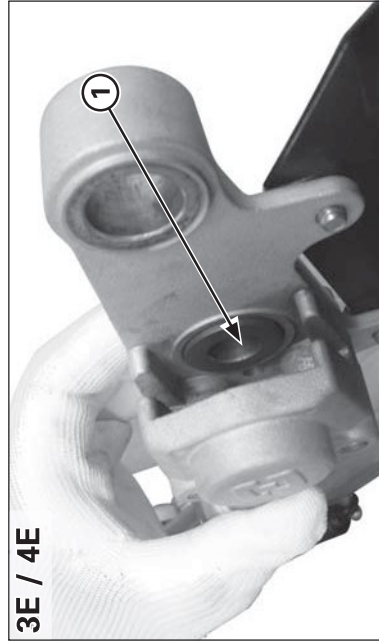

3E / 4E

- (1) CALIPER PISTON

Rear Brake Pad Replacement (3E / 4E)

Remove the rear wheel (page 5-15).
Push the piston all the way in to allow installation of new brake pads.
Check the brake fluid level in the reservoir as this operation causes the level to rise.
Remove the pad pin and brake pads.
Clean the brake caliper inside especially around the caliper pistons.

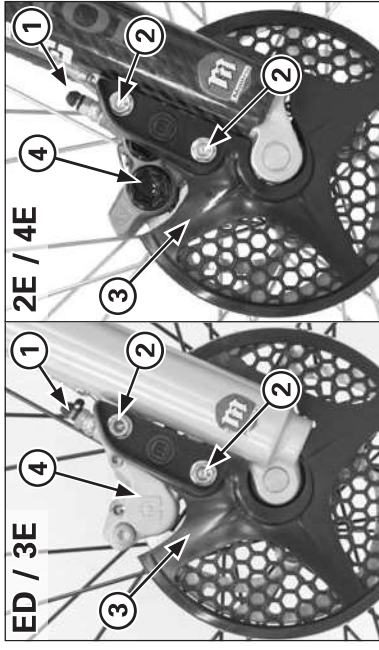

ED / 3E

2E / 4E

- (1) OIL BOLT
- (2) MOUNTING BOLTS
- (3) DISC COVER
- (4) BRAKE CALIPER

Front brake caliper

Removal

NOTICE

*Avoid spilling brake fluid on painted, plastic or rubber parts.
Place a shop rag over these parts whenever the system is serviced.*

Drain the brake system.
Place a clean container under the caliper.

Remove the following:

- Brake hose oil bolt
- Sealing washers
- Brake hose eyelet
- Caliper mounting bolts
- Disc cover
- Flange collars
- Brake caliper
- Spring pin for the pads
- Brake pads (page 5-25, ED/3E version)
(page 5-26, 2E/4E version)