

WHEEL REMOVAL

(Refer to the maintenance precautions on page 62).

Front Wheel Removal

1. Raise the front wheel off the ground by placing a support block under the engine.
2. Remove the speedometer cable set screw (1) and disconnect the speedometer cable (2).
3. Loosen the axle holder nuts (3).
4. Unscrew the axle (4). Remove the wheel.

NOTE:

- * Do not depress the brake lever when the wheel is off the motorcycle. The caliper piston will be forced out of the cylinder with subsequent loss of brake fluid. If this occurs, servicing of the brake system will be necessary. See your Honda dealer for this service.

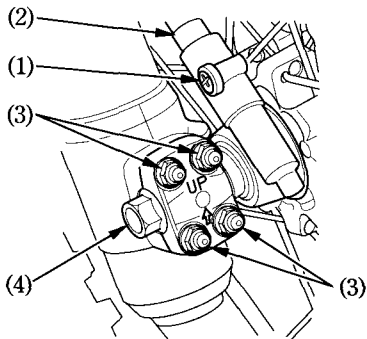

- | | |
|-----------------------|----------------------|
| (1) Screw | (3) Axle holder nuts |
| (2) Speedometer cable | (4) Front axle |