

Fuel Tank

The fuel tank capacity including the reserve supply is:

9.5 l (2.51 US gal , 2.09 Imp gal)

The reserve supply alone is:

1.5 l (0.40 US gal , 0.33 Imp gal)

To open the fuel fill cap (1), pull out the breather tube (2) from the steering stem nut. Then turn the fuel fill cap counterclockwise.

After refueling, be sure to tighten the fuel fill cap firmly by turning it clockwise. Insert the breather tube into the steering stem nut. Use unleaded petrol with a research octane number of 98 or higher.

CAUTION:

* If "spark knock" or "pinking" occurs at a steady engine speed under normal load, change brands of petrol. If spark knock or pinking persists, consult your Honda dealer. Failure to do so is considered misuse, and damage caused by misuse is not covered by Honda's Limited Warranty.

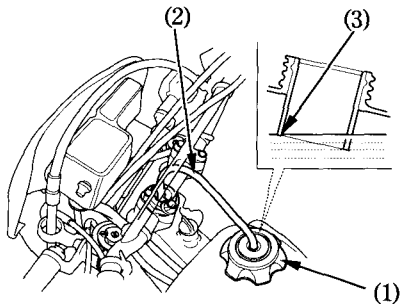

(1) Fuel fill cap
(2) Breather tube

(3) Filler neck