

MAJOR COMPONENTS (Information you need to operate this motorcycle)

▲WARNING

* If the Pre-ride Inspection (page 38) is not performed, severe personal injury or vehicle damage may result.

SUSPENSION

Each shock absorber (1) has 5 adjustment positions for different load or riding conditions.

Use a pin spanner (2) to adjust the rear shocks.

Always adjust the shock absorber position in sequence (1-2-3-4-5 or 5-4-3-2-1).

Attempting to adjust directly from 1 to 5 or 5 to 1 may damage the shock absorber.

Position 1 is for light loads and smooth road conditions. Positions 2 to 5 increase spring preload for a stiffer rear suspension, and can be used when the motorcycle is heavily loaded. Be certain to adjust both shock absorbers to the same position.

Standard position : 2

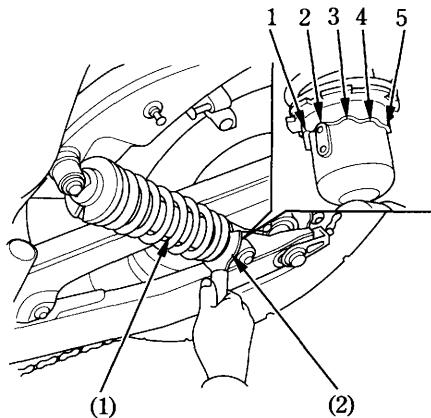

- (1) Shock absorber
- (2) Pin spanner