

PARTS LOCATION AND OPERATION

PARTS LOCATION

- (1) Rear brake lever
Parking brake
- (2) Headlight switch
Engine stop switch
Headlight dimmer switch
Starter button
- (3) Reverse selector knob
- (4) Choke knob
- (5) Fuel gauge
- (6) Ignition switch
- (7) Throttle lever
- (8) Front brake lever

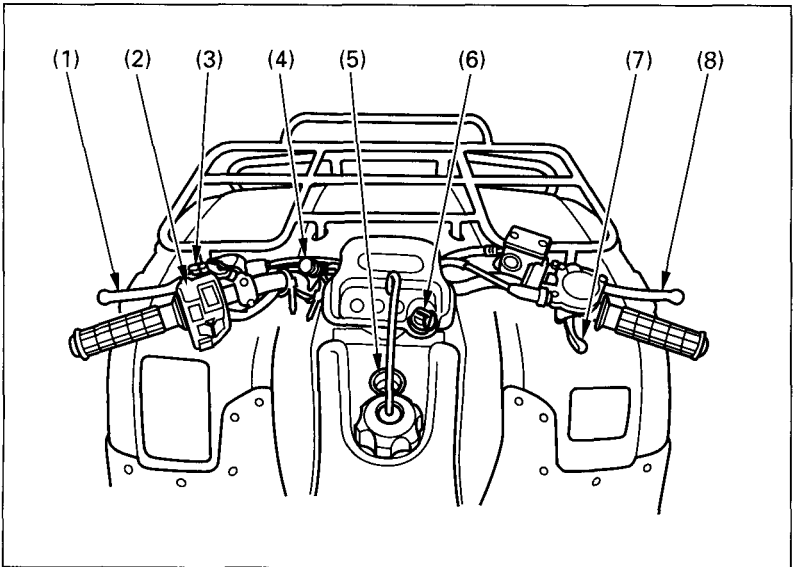

Fig. 2-1

Handlebars, from rider's point of view