

## CARBURETOR

The engine must be warm for accurate idle adjustment. Ten minutes of stop-and-go riding is sufficient.

### NOTE:

\* Do not attempt to compensate for faults in other systems by carburetor adjustment. See your authorized Honda dealer for regularly scheduled carburetor adjustments.

1. Warm up the engine.
2. Adjust idle speed with the throttle stop screw (1).  
IDLE SPEED:  $1,500 \pm 100$  rpm
3. To adjust the fuel mixture, turn the pilot screw (2) clockwise until you hear the engine misses or decreases in speed, then counterclockwise until the engine again misses or decreases in speed. Center the pilot screw exactly between these two extreme positions.

Usually the correct setting (between extremes of rich and lean) will be found to be  $1 \cdot 3/4$  turns open from a fully closed position.

If idle speed changes after adjusting the fuel mixture, readjust the throttle stop screw.

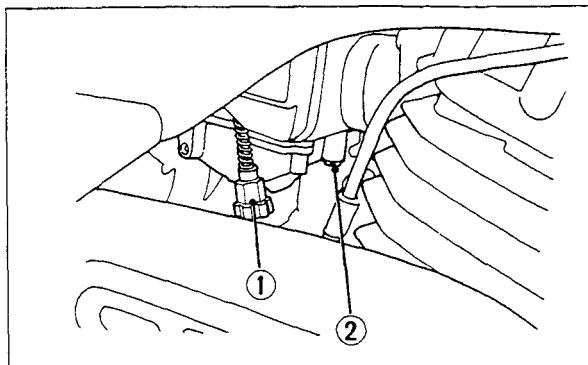

(1) Throttle stop screw    (2) Pilot screw