

THROTTLE OPERATION

Inspect the throttle cable for condition and operation. The cable must not bind or impair smooth operation of the throttle lever in any steering position. Replace the cable if it has become worn or kinked. Lubricate the cable with a commercially available cable lubricant to prevent premature wear and corrosion. Free play, measured at the tip of the throttle lever (1), should be maintained at 3—8 mm (1/8—5/16 in).

The cable adjuster (2) is located near the right grip. Slide the rubber sleeve (3) back to expose the throttle cable adjuster (2). Loosen the lock nut (4) and turn the adjuster to obtain the correct free play. Tighten the lock nut and reinstall the sleeve after adjustment.

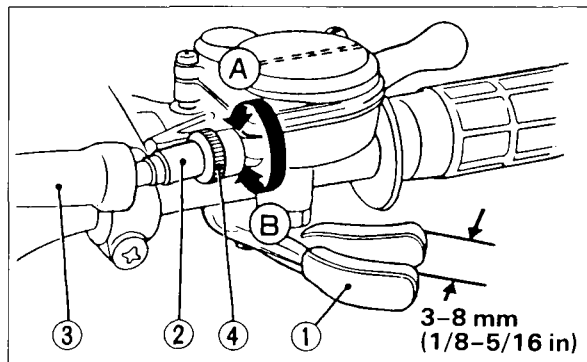

- (1) Throttle lever
- (2) Cable adjuster
- (3) Rubber sleeve

- (4) Lock nut
- (A) Decrease free play
- (B) Increase free play