

ESSENTIAL INDIVIDUAL COMPONENTS

The ST1100 Police is equipped with five, seven; U type, electrical circuits for control of its accessories.

The circuits can be turned on and off by means of the three, four; U type, switches at the right handlebar.

Do not allow the load on the circuits to exceed the following limits when the headlight is in LOW.

CAUTION:

- **Running the engine with the load in excess of the following limits may cause damage to the AC generator.**

Max. Allowable Load

	Headlight (LOW)	Max. allowable load (Patrol lights, siren, etc.)
UK Spain Portugal	55 W × 2	90 W (Equivalent to 3 patrol lights)
Belgium Holland Austria	55 W × 1	145 W (Equivalent to 3 patrol lights + 55 W)
Australia	45 W × 2	110 W (Equivalent to 3 patrol lights + 20 W)

(Except U type)

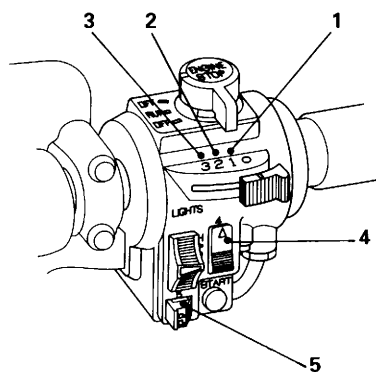

(U type)

