

Inspection

The reserve tank is behind the right middle fairing.

Check the coolant level in the reserve tank (1) while the engine is at the normal operating temperature with the motorcycle in an upright position. If the coolant level is below the LOWER level mark (2), remove the right middle fairing (page 46) and the reserve tank cap (3).

Add coolant mixture until it reaches the UPPER level mark (4). Do not remove the radiator cap.

▲ WARNING

- * Do not remove the radiator cap when the engine is hot. The coolant is under pressure and could scald you.
- * Keep hands and clothing away from the cooling fan, as it starts automatically.

If the reserve tank is empty, or if coolant loss is excessive, check for leaks and see your authorized Honda dealer for repair.

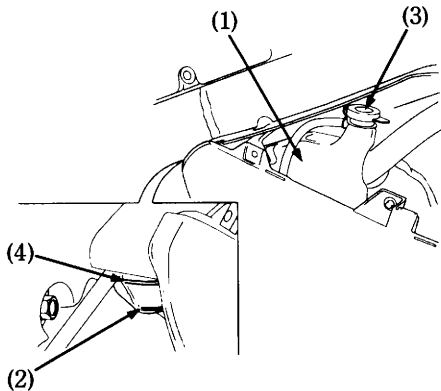

- (1) Reserve tank
- (2) LOWER level mark
- (3) Reserve tank cap
- (4) UPPER level mark