

Personal Fit Adjustments

The following suggestions may make your ride both more comfortable and more responsive to your control input.

Control Positioning

- Position the control levers so that you can use them comfortably when seated and standing.
- Adjust the mounting bolt torque of the clutch and front brake lever assemblies so that they can rotate on the handlebar in a fall. If an assembly does not rotate, it may bend or break a control lever. Make sure that the bolts are torqued securely enough to prevent slippage during normal operation.

Apply Honda Thread Lock or an equivalent to the threads of these bolts prior to adjustment to help ensure the correct torque is retained.

Tighten the top bolts first.

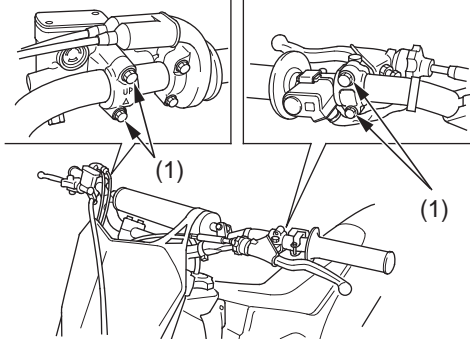

(1) control lever mounting bolts

As an alternative, consider wrapping the handlebar area under the control assemblies with Teflon tape. Then tighten the assemblies to their normal torque. Upon impact, the fully-tightened assemblies should rotate on the Teflon tape.

- Position the shift lever and rear brake pedal so they are close to your boot for rapid access, but not so close that either is depressed when sitting or standing comfortably on your CRF.

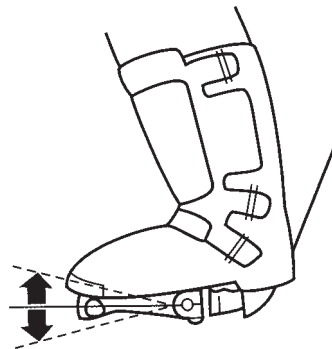

Handlebar Position, Width & Shape

- Position the handlebar so that both gripping the bar and operating the controls is comfortable while both seated and standing, while riding straight ahead and turning. Tighten the forward handlebar upper holder bolts first.
- The handlebar position may be moved forward either 3 mm (0.1 in) (using optional handlebar lower holders) or 6 mm (0.2 in) (by rotating the standard holders 180 degrees). Refer to an official Honda Shop Manual for installation instructions. Be sure to check control cable and wiring harness routing after the adjustment.

- Handlebar width can be trimmed with a hacksaw to better suit your particular shoulder width and riding preference. Think this through carefully and cut off just a small amount at a time from both sides equally. It is obviously much easier to make the handlebar narrower than it is to add material.

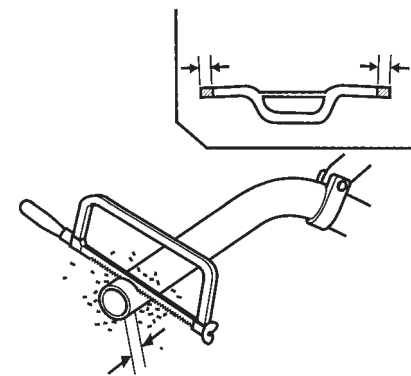

- Chamfer the edges to remove burrs and other irregularities or roughness after sawing the handlebar.
- An alternate handlebar shape, through varying rise or rearward sweep dimensions, will provide further adjustment to riding position and may better suit your particular body size or riding style. Each of the ergonomic dimensions of the machine were determined to suit the greatest possible number of riders based on an average size rider.