

Front Suspension Adjustments

- Remove the fork cap assembly (5) from the fork damper threads and then pop it out by pumping the fork damper piston rod (6) slowly.
- Remove the fork cap assembly (5).

Be careful not to damage the fork cap bushings. Do not disassemble the fork cap assembly. Replace the fork cap as an assembly if it is damaged.

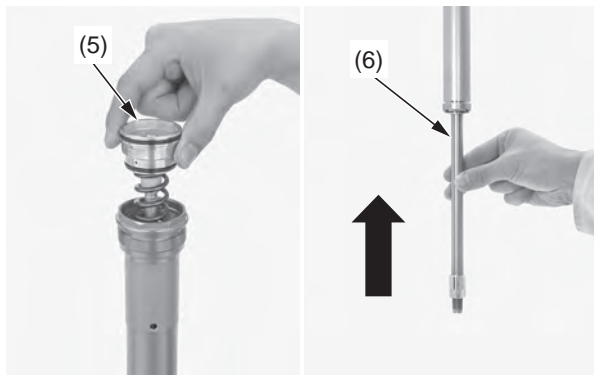

(5) fork cap assembly (6) fork damper piston rod

- Empty the fork oil from the oil holes (7) of the fork damper oil/spring chamber (8) by pumping the damper rod several times.

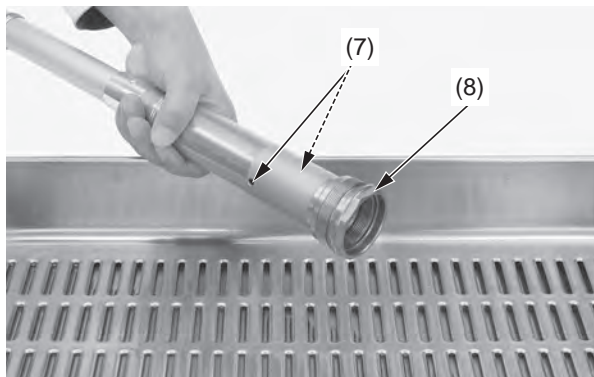

(7) oil holes
(8) fork damper oil/spring chamber

- Clean the fork cap and fork damper threads (9).

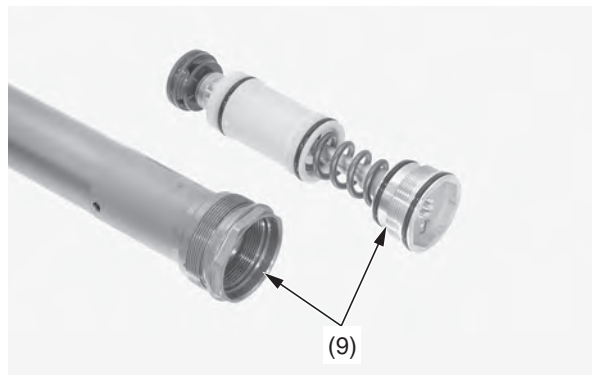

(9) fork cap and fork damper threads

- Extend the fork damper piston rod to maximum length.

Pour the recommended fork oil into the fork damper (1).

Recommended Oil:
KHL15-11 (KYB)

Recommended Amount:
215 cm³ (7.3 US oz, 7.6 Imp oz)

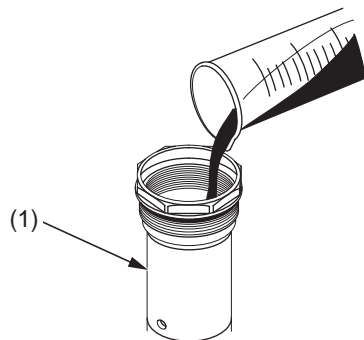

(1) fork damper

- Pump the fork damper piston rod (6) slowly several times to bleed the air from the fork damper (1).

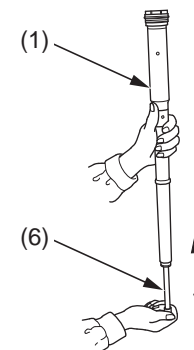

(1) fork damper

(6) fork damper piston rod

- Apply fork oil to the new O-rings (10) on the fork cap assembly (5).

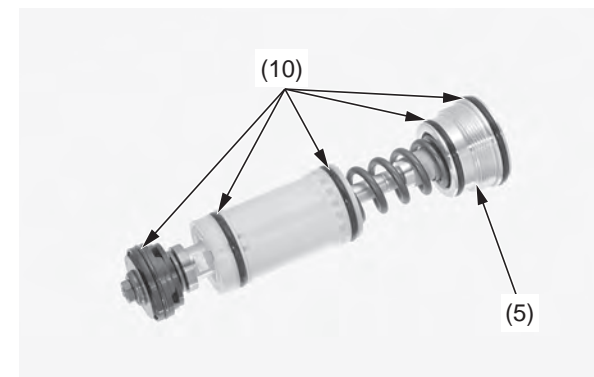

(5) fork cap assembly

(10) O-rings (new)