

Front Suspension Adjustments

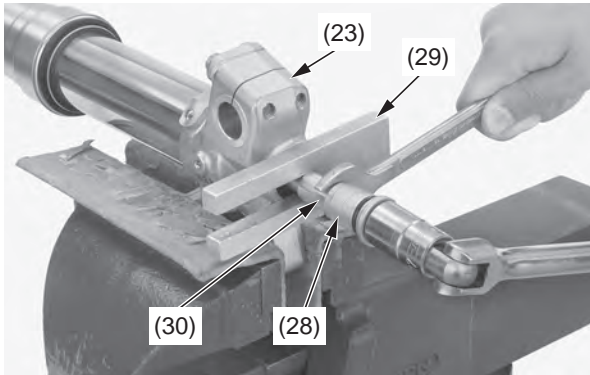

(23) axle holder (29) piston base
(28) fork centre bolt (30) fork centre bolt lock nut

21. Remove the push rod (31) from the fork damper.
22. Remove the piston base (29) or mechanic's stopper tool between the axle holder (23) and fork centre bolt lock nut (30) while pushing the fork damper.

NOTICE

Be careful not to damage the lock nut and fork centre bolt hole.

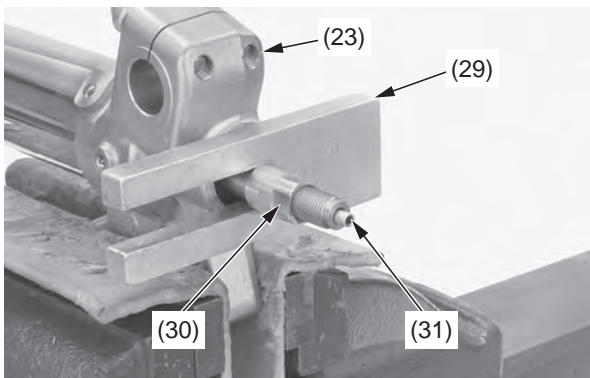

(23) axle holder (30) fork centre bolt lock nut
(29) piston base (31) push rod

23. Remove the fork damper assembly (32) from the fork assembly (33).
Remove the fork from the vise.
Remove the fork spring (34) and spring retainer (35) from the fork assembly. Remove the O-ring (36).

NOTICE

*Do not attempt to separate the fork assembly and drop the axle holder out from the outer tube, which can damage the guide bushings (37).
To avoid damage, hold both the outer tube and slider.*

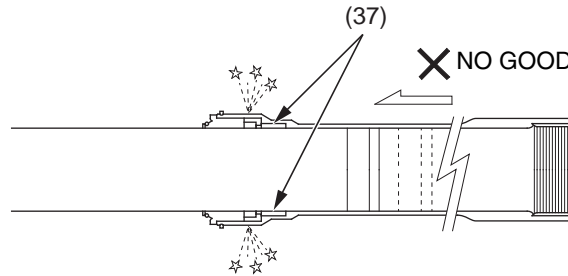

(37) guide bushings

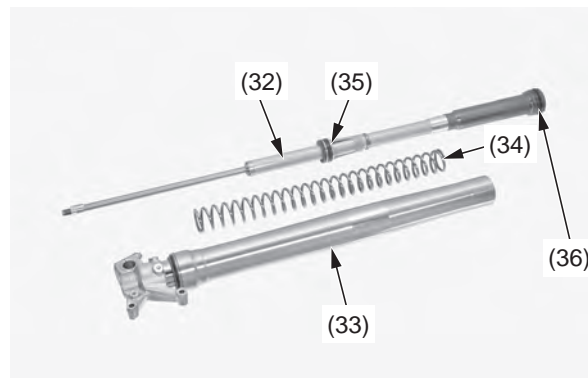

(32) fork damper assembly (35) spring retainer
(33) fork assembly (36) O-ring
(34) fork spring

Damper Oil Change

1. Place the fork damper (1) in a vise with a piece of wood or soft jaws to avoid damage.

NOTICE

Over-tighten the vice can damage the axle holder.

2. Loosen the fork cap assembly (2) while holding the fork damper (1) using the following tools:

- Fork cap bolt holder, 36 mm (3)
070MB-MEN0100
- Lock nut wrench (4)
070MA-MEN0100

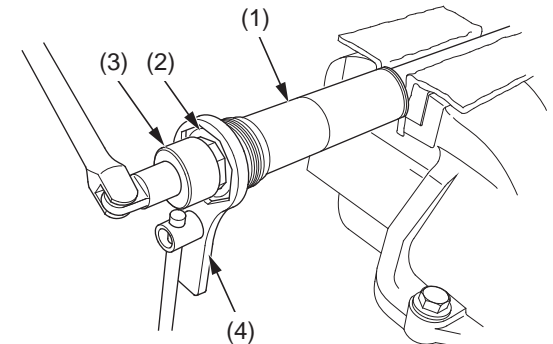

(1) fork damper (3) fork cap bolt holder, 36 mm
(2) fork cap assembly (4) lock nut wrench

(cont'd)