

Steering Damper

Refer to *Safety Precautions* on page 27.

Loose, worn or damaged steering damper components may adversely affect the handling and stability of your CRF. If any steering damper components appear worn or damaged, see your Honda dealer for further inspection. Your dealer is qualified to determine whether or not replacement parts are needed.

Do not attempt to disassemble the steering damper; see your Honda dealer.

The instructions found in this owner's manual are limited to adjustment and service of the steering damper assembly only.

Steering Damper Operation Inspection

- When your CRF is new, break it in for approximately 1 hour to ensure that the steering damper has worked in (page 23).
- After break-in, test run your CRF with the steering damper at the standard setting before making any adjustments.
- Check the spherical bearings and dust seal for dust, dirt, and foreign materials.
- Make all damping adjustments in one-click increments. (Adjusting two or more clicks at a time may cause you to pass over the best adjustment.) Test ride after each adjustment.
- If you have a problem finding an acceptable adjustment, return to the standard position and begin again.

1. Unlock the number plate tab (1) from the handlebar pad.
Remove the bolts (2) and number plate (3).

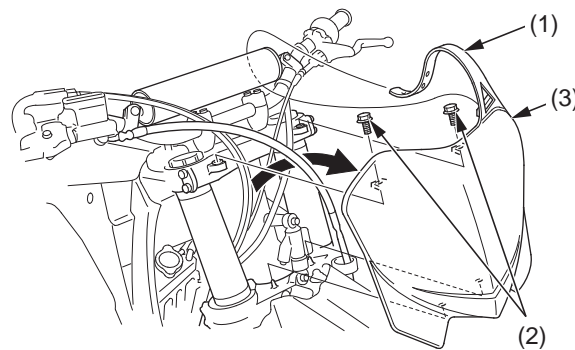

(1) number plate tab
(2) bolts

(3) number plate

2. Check the steering damper (4) for deformation or oil leaks.
Check the damper rod (5) for bending or damage.
Replace the damper case or damper rod if there is any abnormality.
Refer to an official Honda Shop Manual or see your Honda dealer for steering damper disassembly.
Check the torque of the steering damper mounting bolts (6):
20 N·m (2.0 kgf·m, 15 lbf·ft)

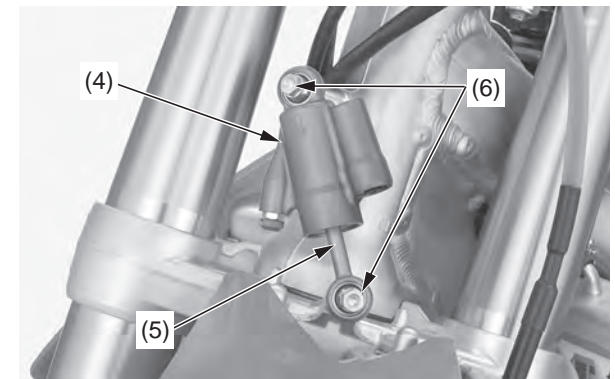

(4) steering damper

(5) damper rod

(6) steering damper mounting bolts