

## Fuel Pressure Relieving

1. Hang the fuel tank to the left side of the frame (page 38).
2. Disconnect the fuel pump connector (1).

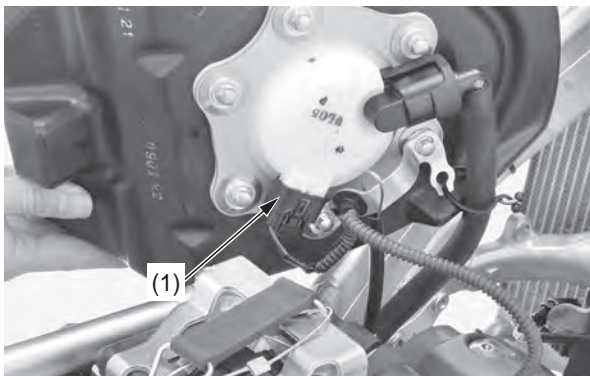

(1) fuel pump connector

3. Reposition the fuel tank and start the engine and let it idle until the engine stalls.

## Fuel Line Replacement

### Disconnection

1. Relieve the fuel pressure (page 45).
2. Hang the fuel tank to the left side of the frame.
3. Remove the fuel quick connect fitting cover (1) from the fuel pump (2).
4. Check the fuel quick connect fitting (3) for dirt, and clean if necessary.

Injector side:

Fuel Pump side:

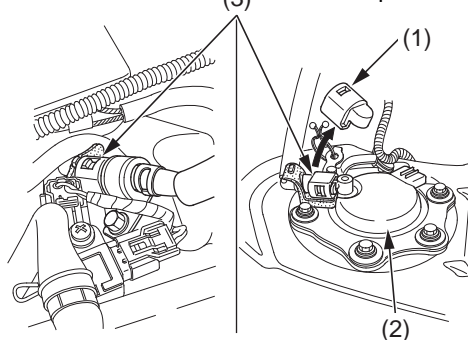

- (1) fuel quick connect fitting cover  
 (2) fuel pump  
 (3) fuel quick connect fitting

5. Remove the bolt (4), clamp and setting rubber (5).

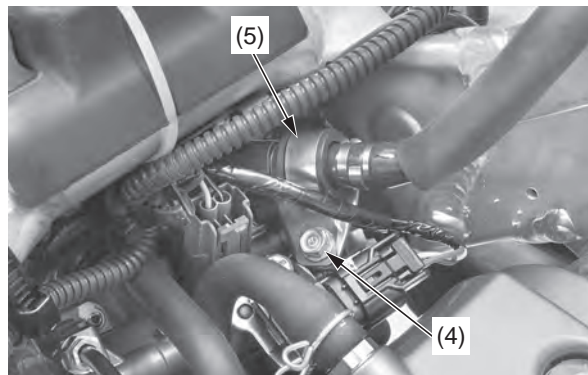

(4) bolt (5) clamp and setting rubber

6. Pull and release the joint rubber (6) of the injector side from the retainer (7).

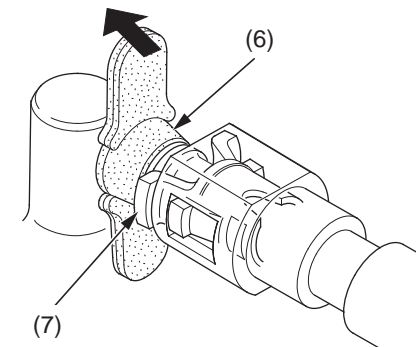

- (6) joint rubber (injector side only)  
 (7) retainer

7. Place a shop towel (8) over the fuel quick connect fitting.

Injector side:

Fuel Pump side:

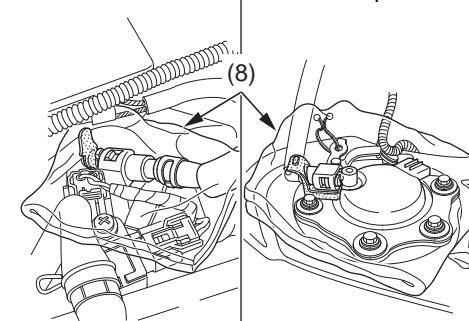

(8) shop towel

(cont'd)