

RIDING

WARNING

- * *Review ATC Safety (page 2) before you ride.*
- * *Ride with both feet on the footpegs at all times. If your feet are off the pegs and touching the ground while the ATC is moving, they may come in contact with the rear wheels, causing injury.*
- * *Avoid “wheelies” and “jumping” as they may cause loss of control.*
- * *The ATC is not designed to be ridden on paved surfaces. Handling and control will be severely affected.*

For your initial riding practice, select a safe area free of obstacles and with an even surface.

1. After the engine has been warmed up, release the parking brake. The machine is ready for riding.
2. While the engine is idling, pull in the clutch lever and depress the gearshift pedal to shift into low (1st) gear.
3. Increase engine speed by opening the throttle; gradually release the clutch lever.
4. When the speed increases, close the throttle, pull in the clutch lever, and shift to 2nd gear by raising the gearshift pedal.

5. This sequence is repeated to progressively shift to 3rd, 4th, 5th and 6th (top) gear.

CAUTION:

- * *Do not shift gears without disengaging the clutch and closing the throttle. The engine and drive train could be damaged by overspeed and shock.*

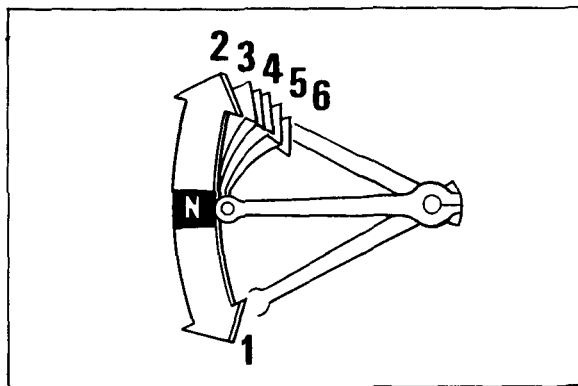

Shifting pattern